

Integrating Detector & CFI Project Overview

**MOLLER Collaboration Meeting
May 2023**

Michael Gericke

- WBS 1.04.02/03 and partial 1.07.02 Overview/Status
 - CFI Project Summary
 - Main Detector Design Status
 - Remaining Design Tasks
 - Equipment/Parts Purchase and Production Status/Schedule
 - Quality Assurance Plans
 - Assembly and shipment

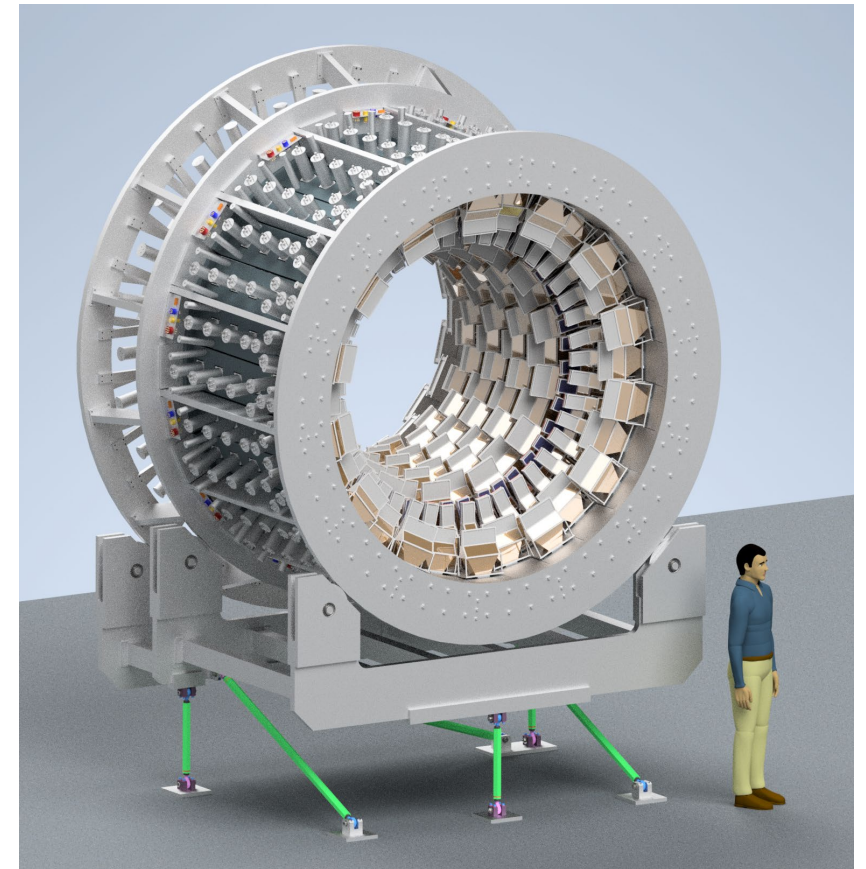

CFI: Canada Foundation for Innovation

CFI Team:

Michael Gericke (PI)

Juliette Mammei (Co-PI)

Wouter Deconinck (Co-Applicant)

Jeff Martin (Co-Applicant)

Russell Mammei (Co-Applicant)

Svetlana Barkanova (Co-Applicant)

Aleksandrs Aleksejevs (Co-Applicant)

Eli Korkmaz (Co-Applicant)

The MOLLER CFI:

- The MOLLER CFI total is \$6,075,440 CAD (~ \$4,700,000 US).
- This splits up as follows:
 - Federal Government: \$ 2,336,900 (CAD)
 - Province of Manitoba: \$ 1,638,540 (CAD)
 - Partners: \$ 2,100,000 (CAD)
 - Operating fund: \$ 600,000 (CAD)
- Partner funds:
 - DOE and NSF budgets: Detector cabling, mounting, and DAQ infrastructure
 - Some industry discounts
 - Institutional (University) support
- Institutional Operating Fund (IOF):
 - Technical personnel (technician and engineering) for maintenance and operation
 - Material and equipment for upkeep and maintenance
- Present end of project is scheduled for Oct. 31, 2024 (can request an extension). Operating fund normally starts after that.
- Canadian MOLLER NSERC grant was just renewed CAD 1,140,000 for the next three years (~70% increase)

Detector Array Design

Proposed detector nomenclature and numbering:

- Septant



- Sector (open, transition, closed)



Open

Transition

Closed

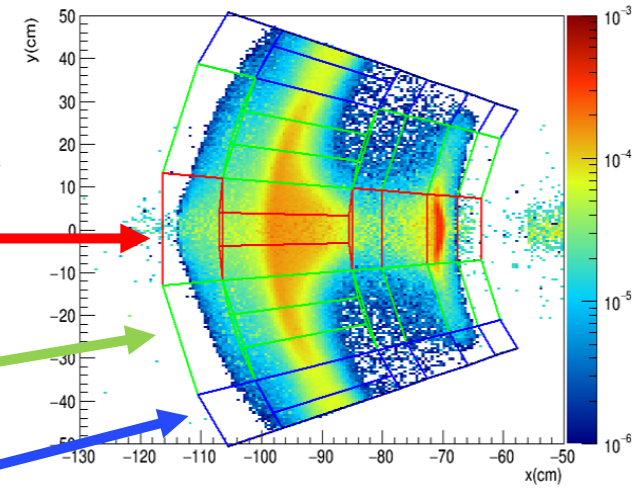

- Segment (one of 28)



- Module

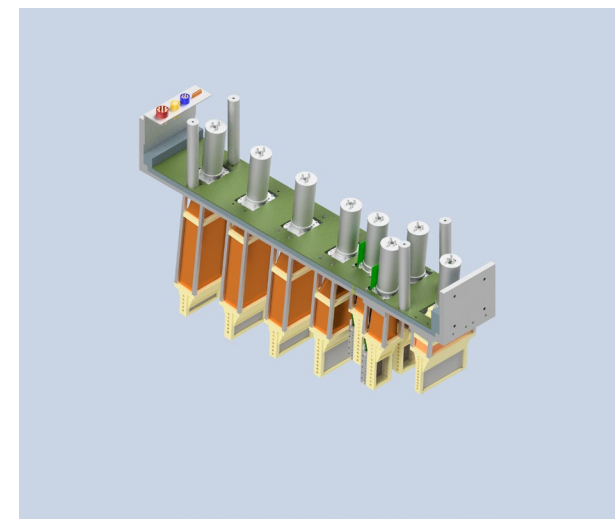
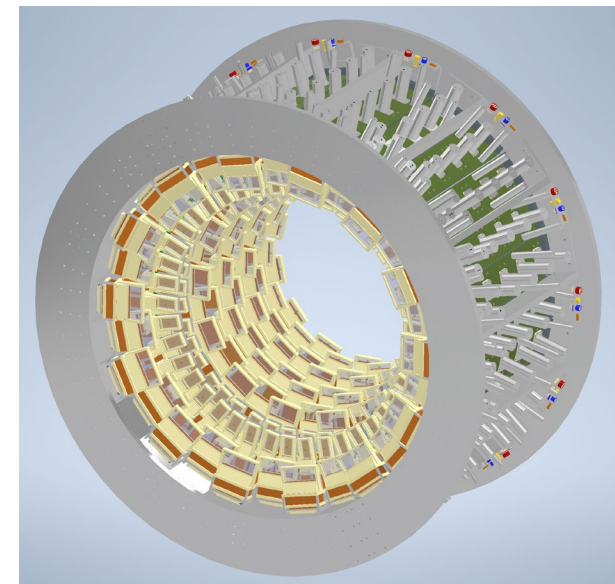
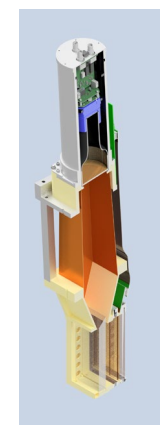

Requirements

1. Radial segmentation

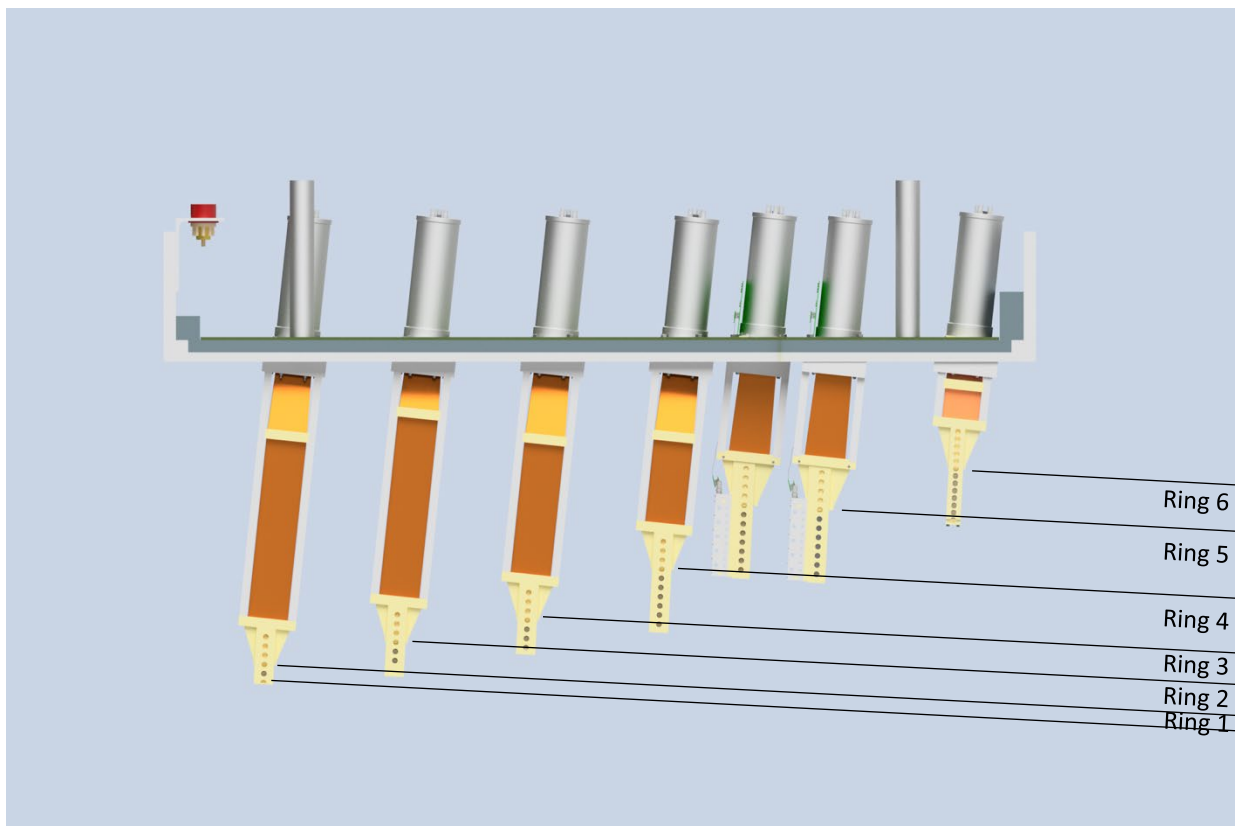

The detector array is separated into six rings:

- Ring 1- 4: $e + p \rightarrow e + p$ and $e + p \rightarrow e + X$
- Ring 5: $e + e \rightarrow e + e$
- Ring 6: Radiative tail

Radial distribution at detector plane 26.5 m from target

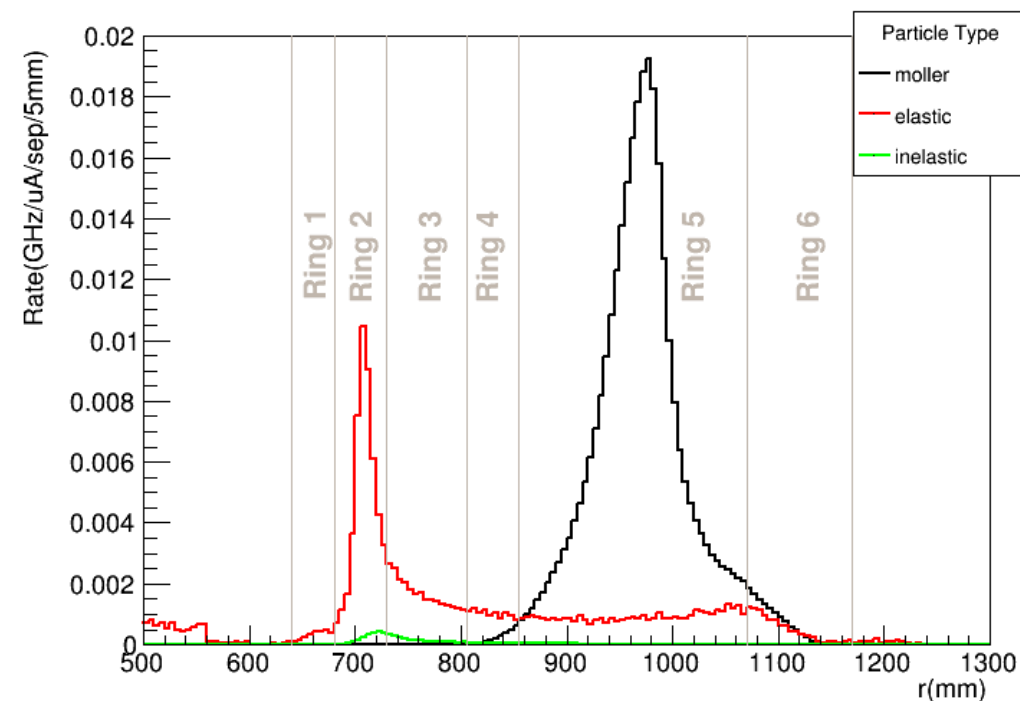

Overall Thin Detector Module Design

Module parts:

- Fused silica active volume
- Air core light guide
- PMT
- Front-end electronics
- HVMAPS module
- Rigid by light-weight structure
- Shown here is ring 5 – the other rings have the same parts.

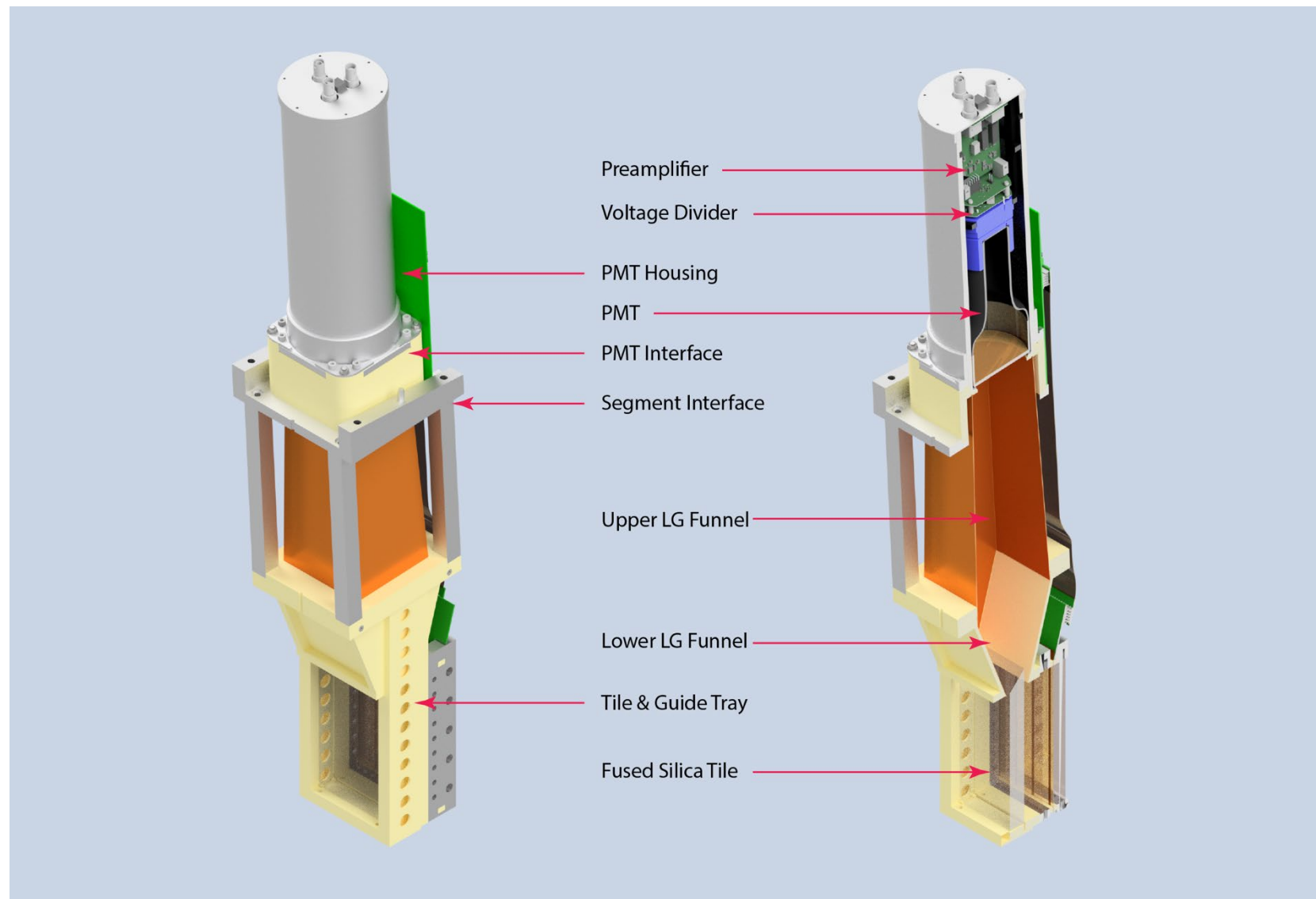

Module Mounting Structure Design

- For ring 5 several versions of the module mounting structure have been implemented in CAD and were constructed
- CAD design of the other rings is completed; rings 1-3 have same construction as ring 4 shown here
- Ring 6, 1, and 2 structures have been built

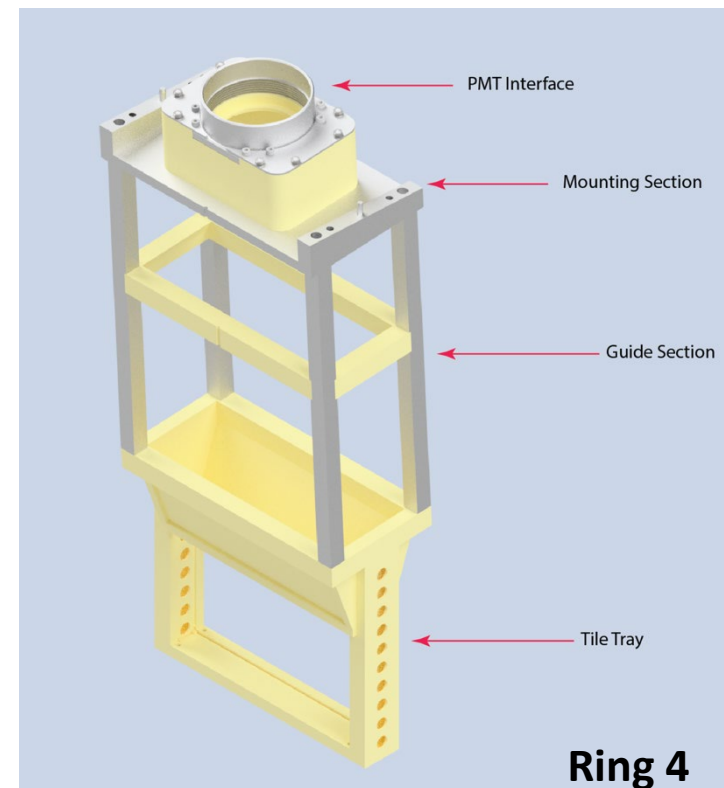
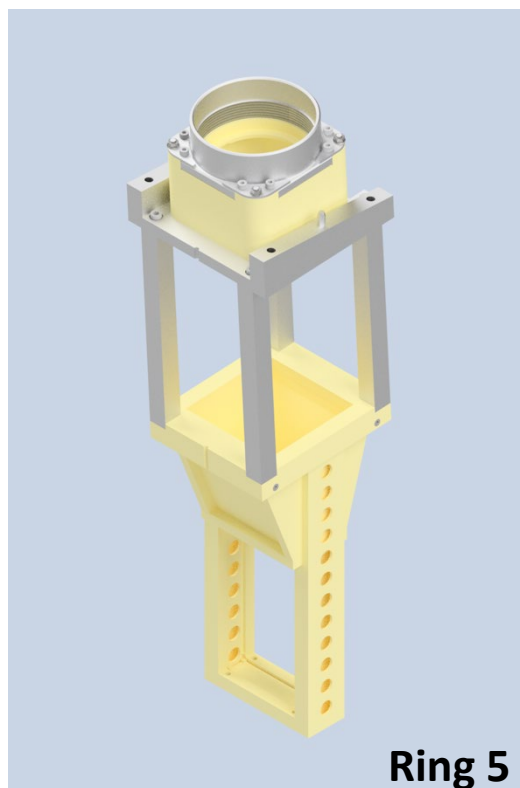
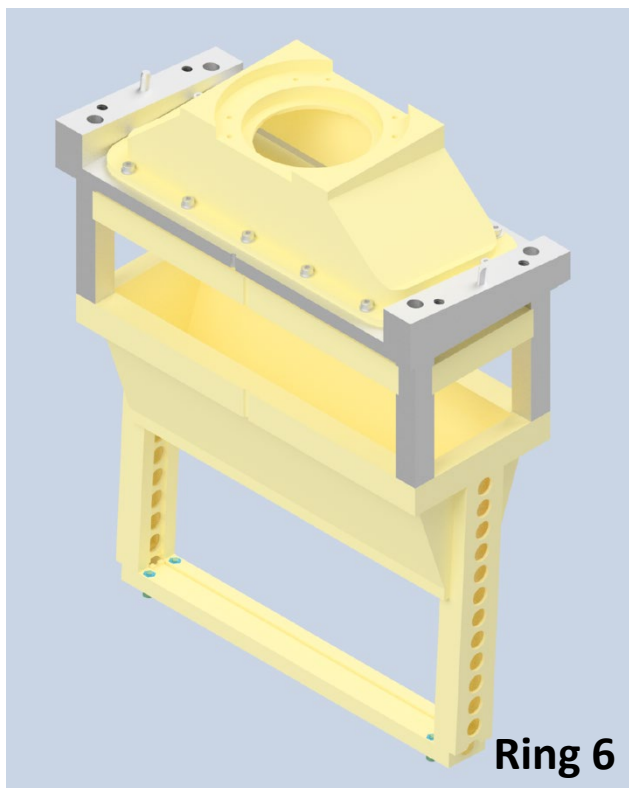

Module Mounting Structure Design

- The quartz tray (right) fixes the most important relationship in the design - the angle between the quartz tile and primary reflector.
- The middle section holds the light guide geometry defined and in place.
- The top section provides a secure and accurate interface with the PMT – easy attachment and removal

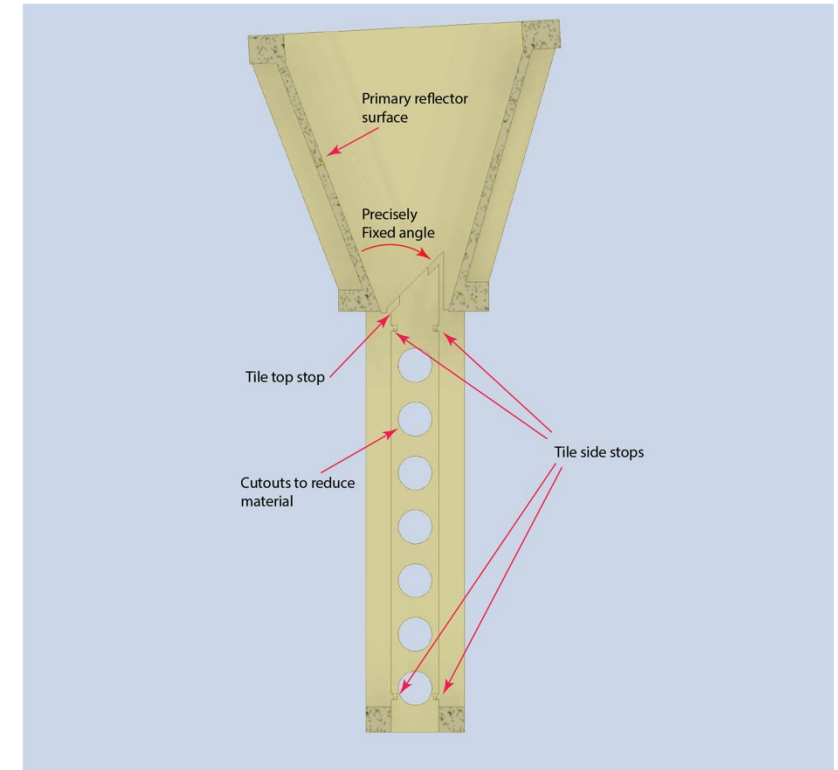
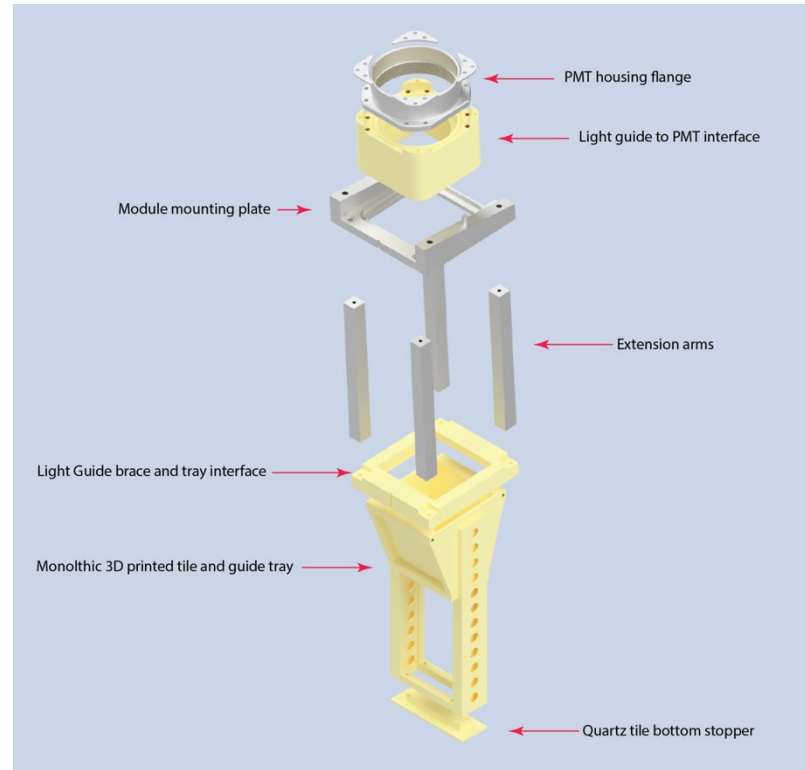
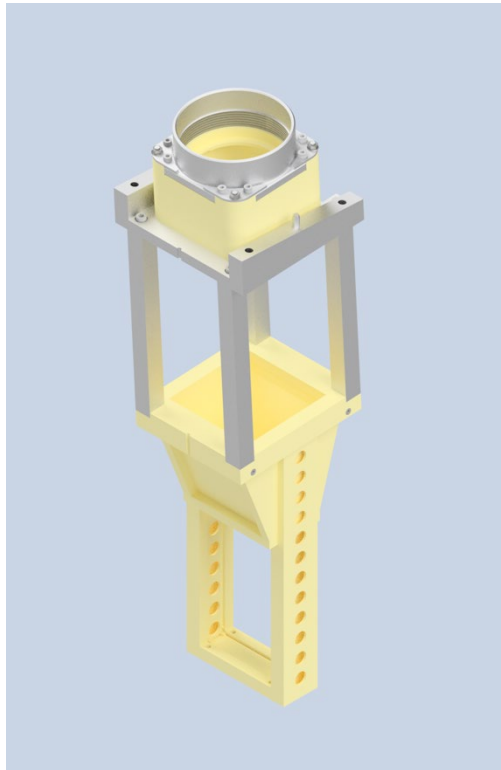

Main Detector Design Status:

- The detector tiling is nearly (~98%) finalized:
 - The tiles are positioned and sized in accordance with the deconvolution/error analysis (Zuhal's talk) and physical requirement
 - Small tweak may be implemented (e.g. ring 1) to minimize cross-talk
 - This means that the module/part sizes are final
- Module structure:
 - See next slides and Brynne's talk ...
 - Materials testing is progressing (radiation hardness and humidity) – carbon-fiber ABS seems material of choice
 - Ring 1,2,5, and 6 modules were constructed for beam tests
 - Ring 1 was tested for deflection (maximum cantilever)
 - PMT housing redesign nearly finished (95%) – see Brynne's talk
 - Module cooling and air flushing simulations nearly completed (See Laheji's talk)
- Mounting Structure and Cabling
 - Mounting structure is nearly final (see Larry's talk)
 - Cabling planning in progress (See Dustin's talk)

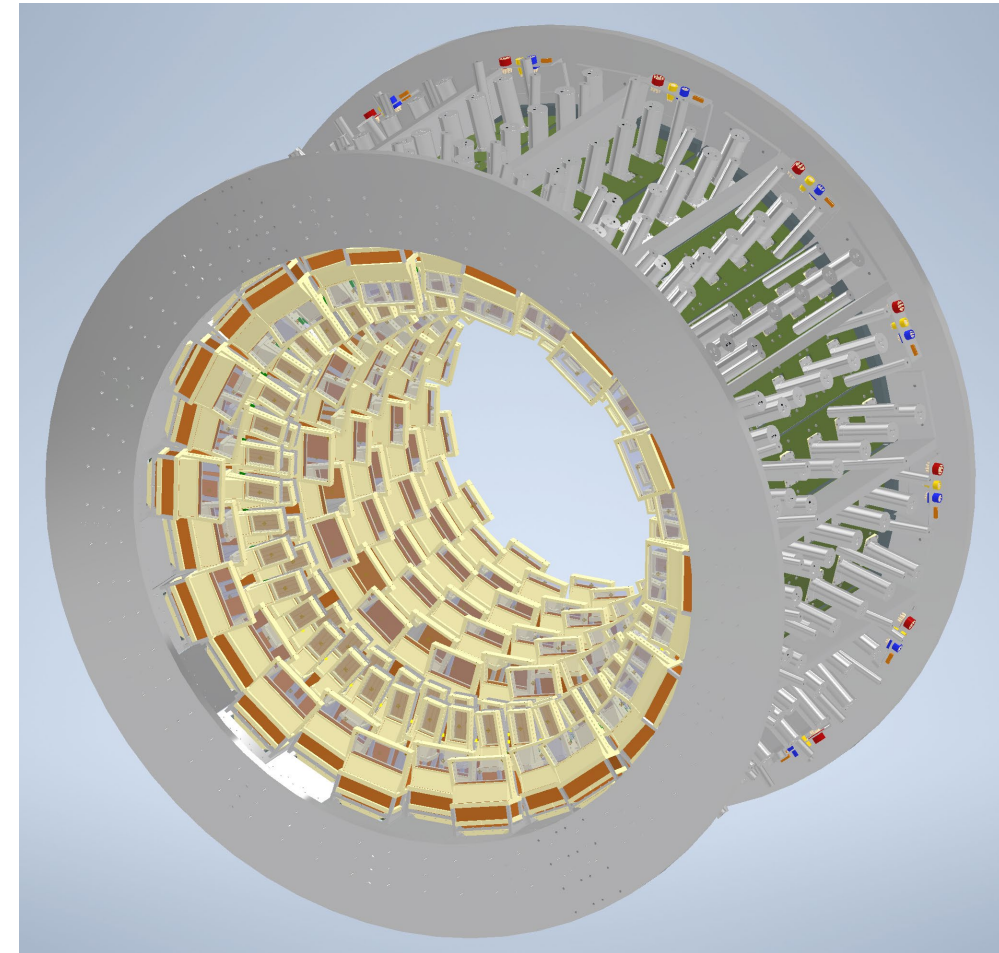

Main Detector Design Status:

- Front-end electronics (see Jie’s talk for details)
 - Voltage divider design is complete – switching between event mode and integration mode included
 - Event mode amplifier is undergoing small redesign to address high frequency noise
 - Integration mode amplifier is undergoing DC/DC converter redesign to address radiation hardness concerns and improve power supply needs
 - Power supply modules and cable needs have been identified (cables see Dustin’s talk)

- ADC board progress
 - The ADC board is fully functional with Firmware running to take streaming data (firmware for helicity averages exists but is not currently read out)
 - The board runs a full linux operating system and interfaces via fiber to the backend DAQ
 - The TI interface has been tested and CODA has been implemented on the board SoC
 - One more prototype needed to address minor issues of the front-end (filters etc.)

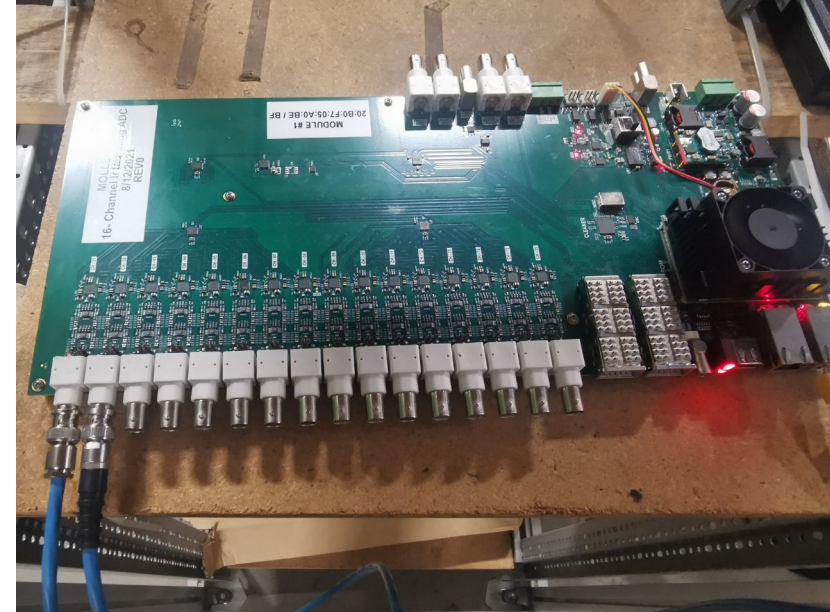
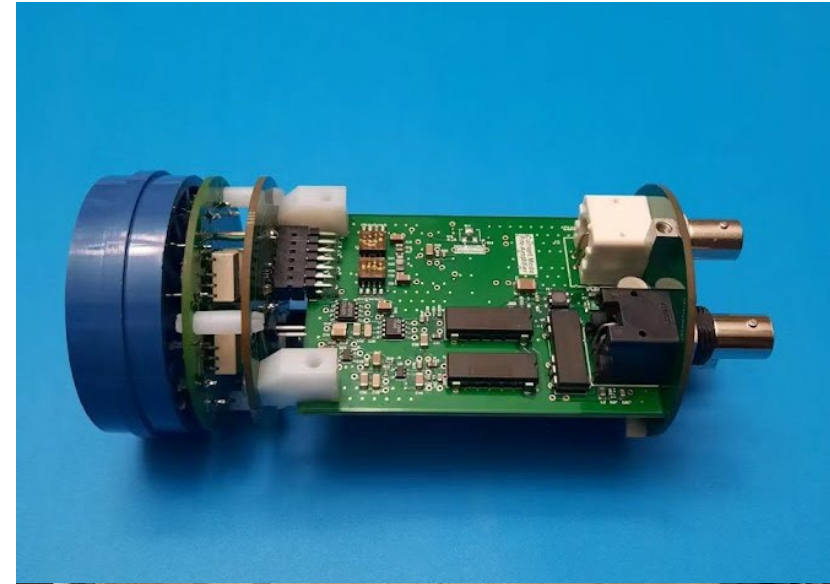

Main Detector Design Status:

- ADC board progress
 - Readout software suitable for benchtop running and prototyping / Q&A testing of PMT electronics exists
 - We have to take a second look at the front-end filter of the board to make sure that we have clean roll-off
 - Presently a gate/trigger can be fed to the board via two lemo connectors at the back. Final trigger will come from the TI interface

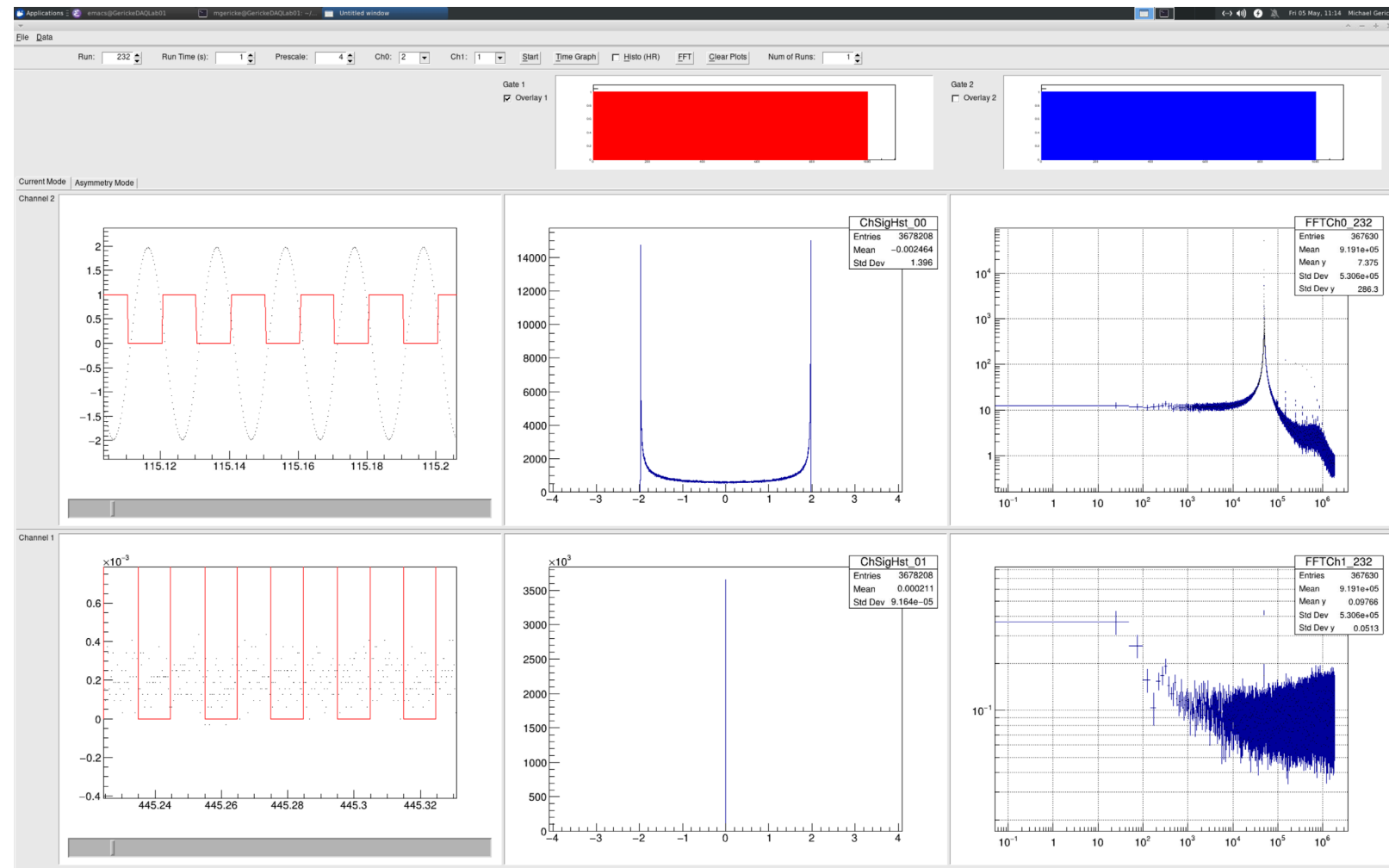
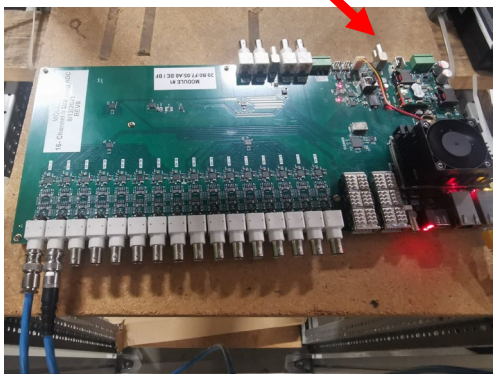

We need a second prototype – to be done this summer

Remaining Design/Prototyping Tasks:

- Detector structure (all of these should be done by the end of the summer – most sooner):
 - Minor tile position and size tweaks, based on tile overlap and deconvolution analysis
 - Minor changes to the mounting structure (split the quartz tray structure)
 - Light – tight sealing design (with air exit)
 - Finishing the details of the PMT housing assembly
 - Final choice of material for 3D printing (most likely carbon-fiber ABS, but need additional radiation tests of pieces exposed to various moisture levels)
 - Final light guide material choice
 - Verify final designs/prototypes in beam test and with cosmic rays
- Front-End Electronics
 - Small changeout for the modified amplifiers (event mode and integration mode)
 - Verify and implement changes to the ADC board front-end and build a second prototype
- Mounting Structure and Cabling
 - Complete mounting structure and cabling infrastructure (again, see subsequent talks)

Equipment/Parts Purchase and Production Status/Schedule:

- Quartz tiles:
 - Raw material suppliers have been identified (Heraeus, Corning) - either Heraeus for all tiles or only for the high-rate tiles and Corning for everything else
 - Potential company to do the polish is has been identified – we are getting a number of tiles from the company (Corning now and shortly also Heraeus)
 - We need one more beam (June 2023) test to make final decision on the polish quality – requested CFI to cover associated cost overrun and need to make a decision in June, before request goes to CFI board for approval.
 - We foresee placing the full quartz order by early Fall 2023
- Mounting structure/ PMT housing:
 - These will be in-house production at UManitoba and UMass with the possible exception of some of the aluminum parts that require high precision CNC
 - Purchase of 7 new large production volume 3D printers is imminent – anticipate a full year of 3D printing effort split between UMass and UM
 - Light-guide material will be a standard item purchase (generally available)
- PMT/Front-End Electronics
 - The PMT order has been placed – we are scheduled to start receiving 20/month starting in July – to have final shipment sometime in early Fall 2024
 - PCB production: many companies to choose from – we have several that we have been using for prototypes
 - Chip level components – many with long lead times are on order (e.g. ADC chips) – or will be ordered shortly (amplifiers)
 - ADC board FPGA modules are all on hand

Quality Assurance Plans:

- Quartz tiles:
 - Visual inspection
 - We have access to a high-quality laser reflectometer we can use to spot check the quality of the received quartz tiles

- Mounting structure
 - Visual and fit tests as we go along in the production
 - Thinking about computerized vision with a high-resolution camera to verify dimensionality of items
 - Strength/deformation/deflection tests (spot check – after assembly)

- Electronics
 - Test bed exists from prototyping – establish a procedure to measure noise performance on the bench
 - With the ADC board and the first PMTs in hand, we can test the electronics in a realistic setup (see also PMT test setup next slide below)

- PMTs
 - Single PE rate and Gain tests
 - QE measurements
 - Linearity measurements (exercises the FE electronics chain)

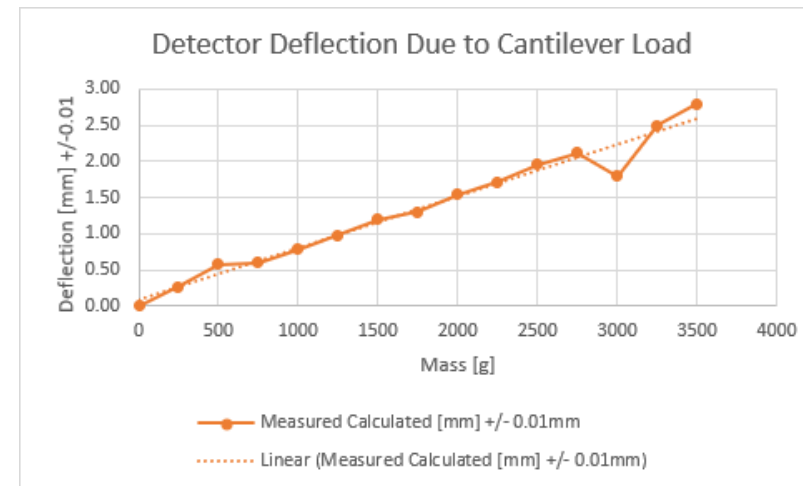

Measured roughly 0.1 to 0.2mm increase in deflection over 6 days under its own weight. Never exceeded 0.5 mm

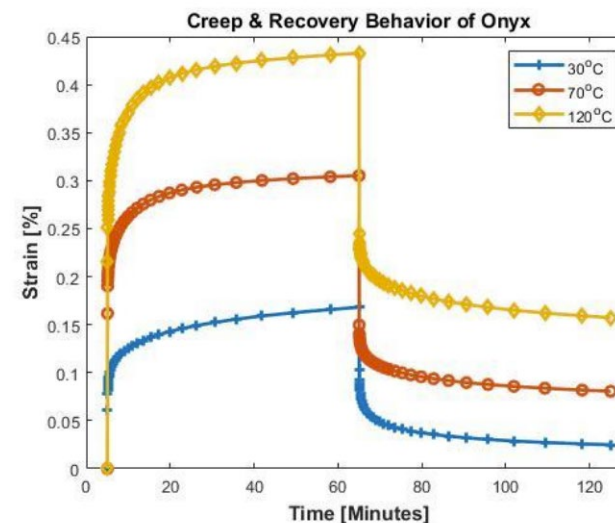

Quality Assurance Plans:

Integrating Detector PMT QA

1

Slide from
Savino Longo

- PMTs are scheduled to start arriving at U. Manitoba in July (~20/month).
- PMT QA will include non-linearity and quantum efficiency measurements.
- Below shows apparatus being prepared for non-linearity measurements (Anuradha Gunawardhana). Based off design used for PREX-2 and CREX (D. Adhikaria and D. McNulty).
 - ➔ Will benchmark PMT non-linearity as function of gain, current, wavelength.
- Separate apparatus for Quantum Efficiency vs. wavelength measurement also being prepared.

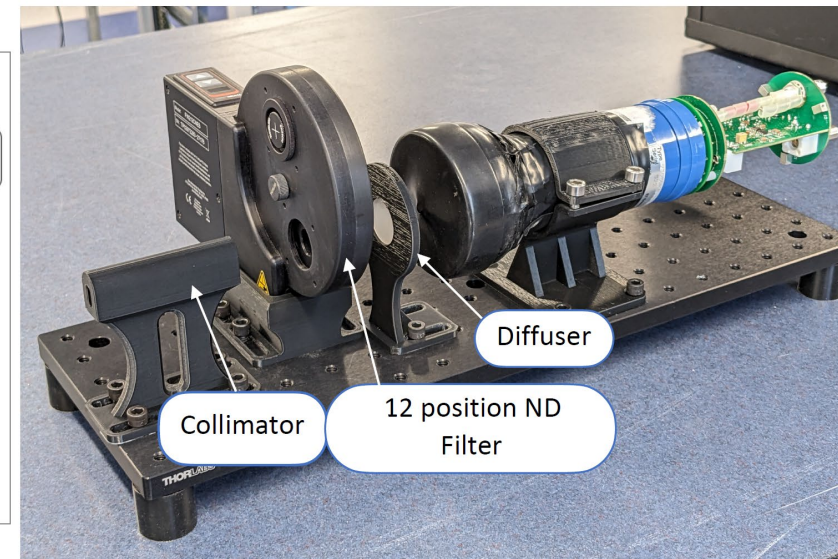
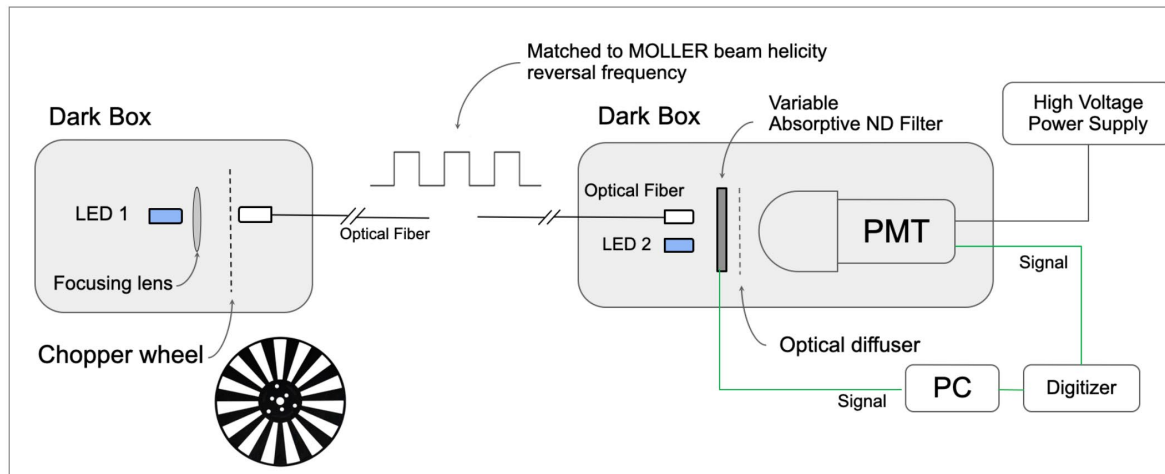

Assembly and Shipment:

- Module assembly will take place at UofM and UMass
- If everything goes well a partial number of modules can probably start to be shipped to W&M by June 2024
- Quartz tile shipment will likely continue throughout 2024, with the last ones arriving possibly as late as May 2025 (pessimistic view)
- UofM students to temporarily relocate to W&M to finalize assembly into the segments
- Suggest to wait with PMT module installation until segments arrive in Hall A
- In segment cable routing can be done before PMT installation

Reasonable Schedule:

Line Item	CFI Item	CFI Budget	2022												2023												2024												2025						
			Jan	Feb	Mar	Apr	May	Jun	Jul	Aug	Sep	Oct	Nov	Dec	Jan	Feb	Mar	Apr	May	Jun	Jul	Aug	Sep	Oct	Nov	Dec	Jan	Feb	Mar	Apr	May	Jun	Jul	Aug	Sep	Oct	Nov	Dec	Jan	Feb	Mar	Apr	May	Jun	Jul
16	Detector Module Procurement or Fabrication																																												
17	Procurement Package for Production Quartz	1																																											
18	Vendor effort for Production Quartz	1																																											
19	Vendor effort for polishing quartz	1																																											
20	RCV: Production Quartz	1																																											
21	Procurement Package for Phototubes	1																																											
22	Vendor effort Phototubes	1																																											
23	RCV: Phototubes	1																																											
24	Procurement Package for Production Light Guide Parts	1																																											
25	Vendor effort Production Light Guides Parts	1																																											
26	RCV: Production Light Guide Parts	1																																											
27	Procurement Package for Production Detector Mechanical Materials	1																																											
28	Production effort for Production Main Detector Mechanical Parts	1																																											
29	RCV: Production Main Detector Module Mechanical Parts	1																																											
30																																													
31	Detector Module Assembly and Test																																												
32	Inspect Production Quartz	1																																											
33	Inspect Production Phototubes	1																																											
34	Inspect Production Air Light Guides	1																																											
35	Inspect Main Detector Modules Mechanical Parts	1																																											
36	Assemble Production Main Detector Module Structures	1																																											
37																																													
45	Detector Module Electronics																																												
47	Procurement Package Phototube Bases	1																																											
48	Vendor effort Phototube Bases	1																																											
49	RCV: Phototube Bases	1																																											
50	Inspect Production Phototube Bases	1																																											
51	Procurement Package for HV PS Main Frames	1																																											
52	Vendor effort HV PS Main Frames	1																																											
53	RCV: HV PS Main Frames	1																																											
54	Procurement Package for HV PS Modules	1																																											
55	Vendor effort HV PS Modules	1																																											
56	RCV: HV PS Modules	1																																											
57	Procurement Package for LV Power Channels	1																																											
58	Vendor effort LV Power Channels	1																																											
59	RCV: LV Power channels	1																																											
60	Preamplifier Procurement Package	2																																											
61	Vendor effort Preamplifier	2																																											
62	RCV: Preamplifier	2																																											
63	ADCs Procurement Package	2																																											
64	Vendor effort ADCs	2																																											
65	RCV: ADCs	2																																											
66	Fabricate ADC Housing	2																																											
67	Inspect ADCs	2																																											
68	Inspect Preamps	2																																											