

# MOLLER Meeting at Jefferson Lab

## MOLLER Upstream Spectrometer Design

- Status of upstream design effort
- CD-3a Components and Justification
- Vacuum chamber and support

Ernie Ihloff, MIT Bates

May 5, 2023

 Jefferson Lab

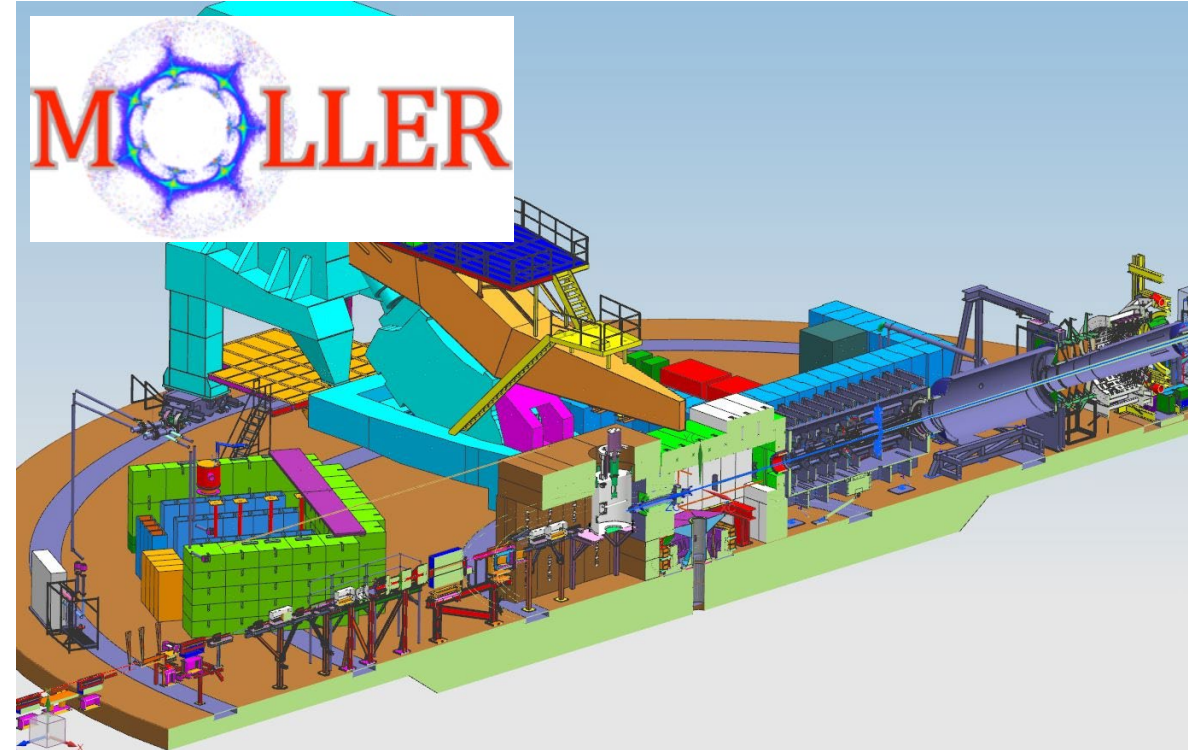

# Outline

- CD-3a items, time line and justification.
- Design of Vacuum chamber and support with FEA results of stress and deflections
- EH&S and ALARA considerations in engineering design
- Work with Jefferson Lab design authority to insure compliance and an approved design
- Summary

- Team Members:
  - Ernie Ihloff, MIT Bates
  - Danielle Petterson, MIT Bates
  - Jason Bessuille, MIT Bates
  - Tricia Smith, MIT Bates
  - Jim Kelsey, MIT Bates

All work done in conjunction with the Jlab MOLLER engineering team and under guidance of the MOLLER collaboration

Jlab Magnet group has been an integral part of the design review process

## General: MOLLER Experiment Upstream Toroid

The upstream toroid system starts approximately 5 meters downstream of the Liquid Hydrogen target in Hall A at Jefferson Lab. This subsystem includes the following items:

- Large vacuum chamber with base flange support for all items inside, removable top cover
- Movable Blocker and Sieve Blocker with remote control plus interlocks. (Jason's talk)
- Collimators #1 and #2 (Jason's talk)
- Upstream 2 meter long ,7 coil magnet (no iron) that operates in a modest vacuum
- Electrical power feed design and water to Spectrometer coils
- Collimator #4 (Jason's talk)
- Downstream lead shield
- MIT design scope does not include Chamber frame support to Hall floor

# Upstream Toriod

- Upstream chamber shown with all subsystems

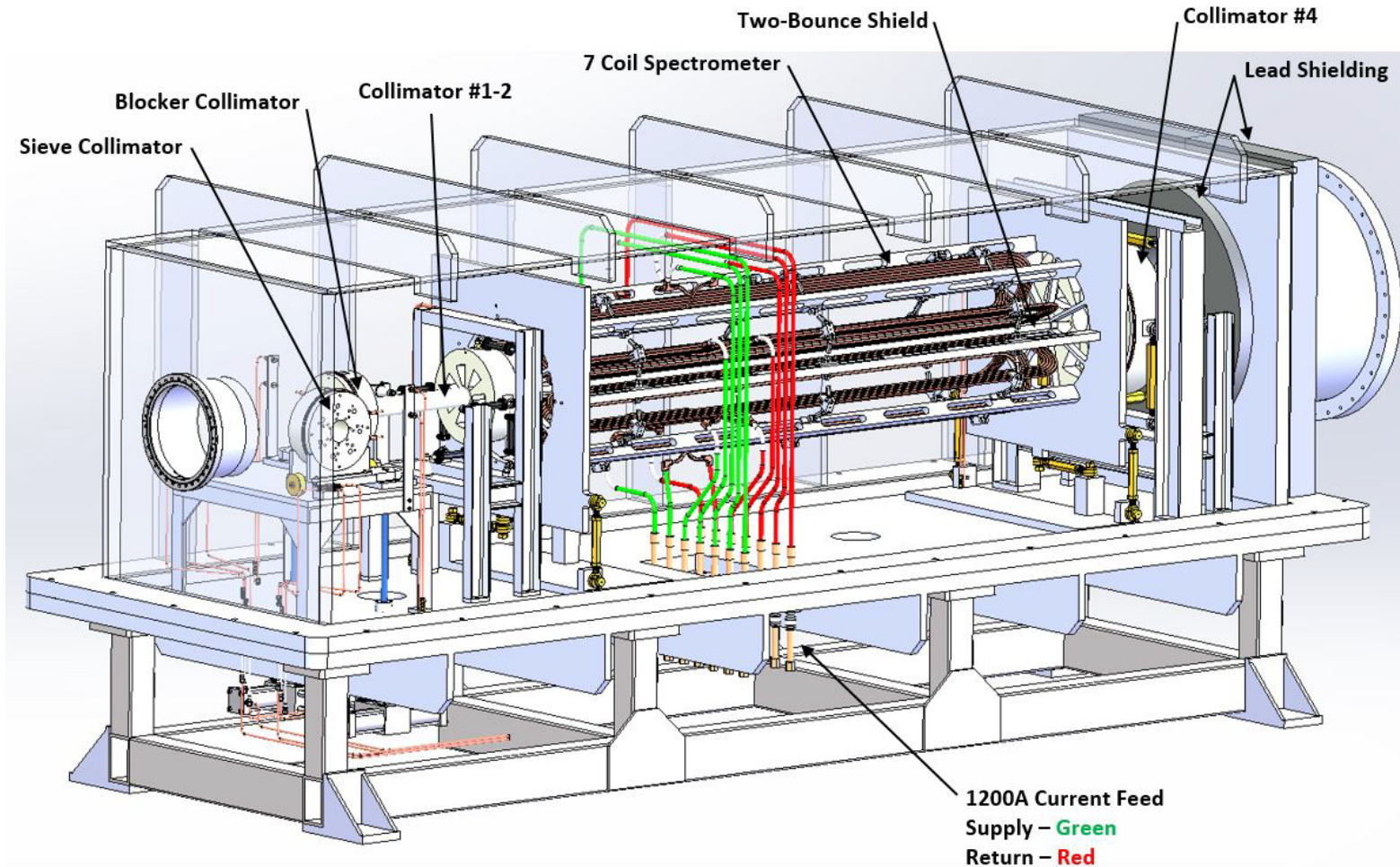

# Upstream Spectrometer

- Tungsten plates are being added to limit oring radiation dose per modeling

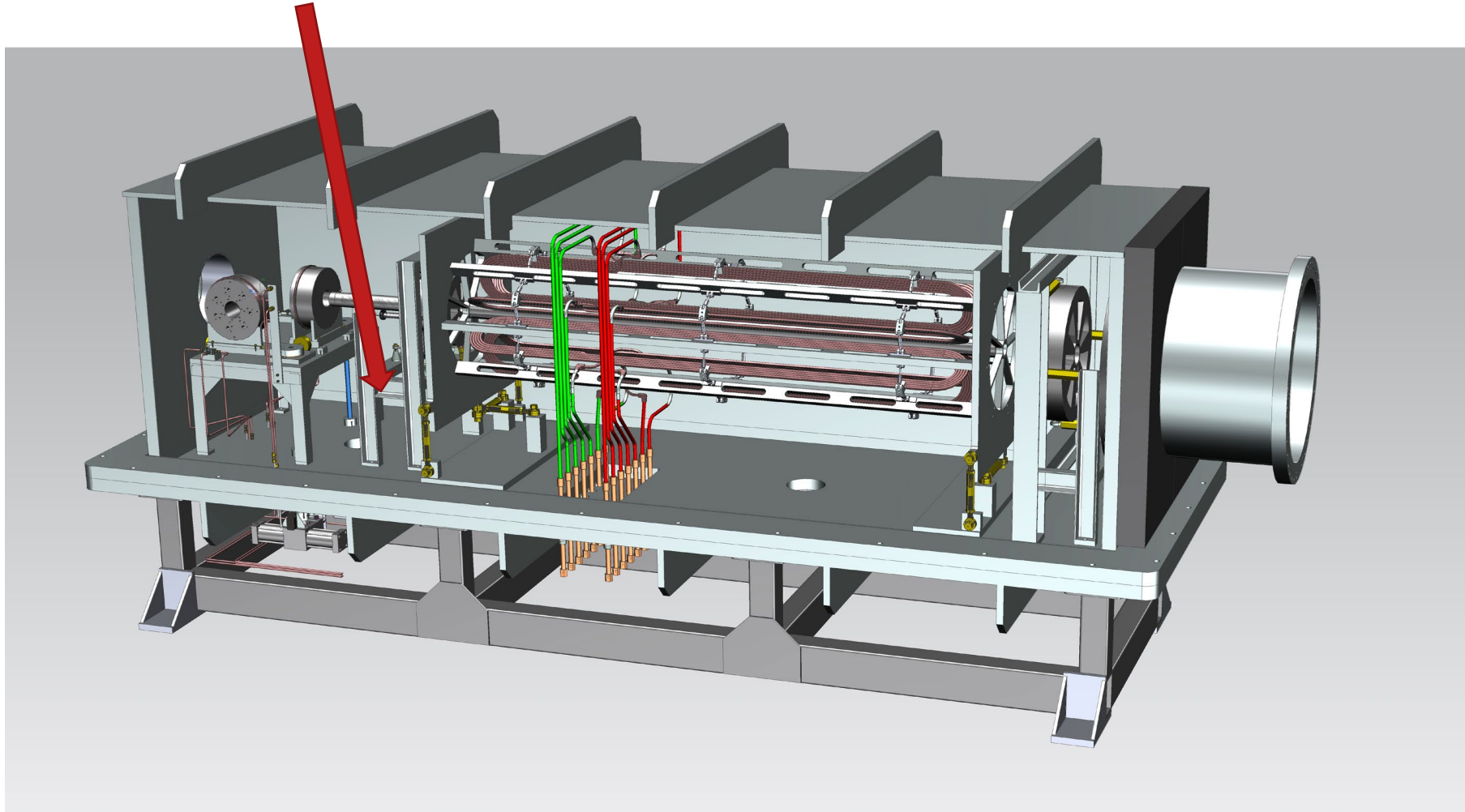

# Upstream Spectrometer Tungsten coil sheet

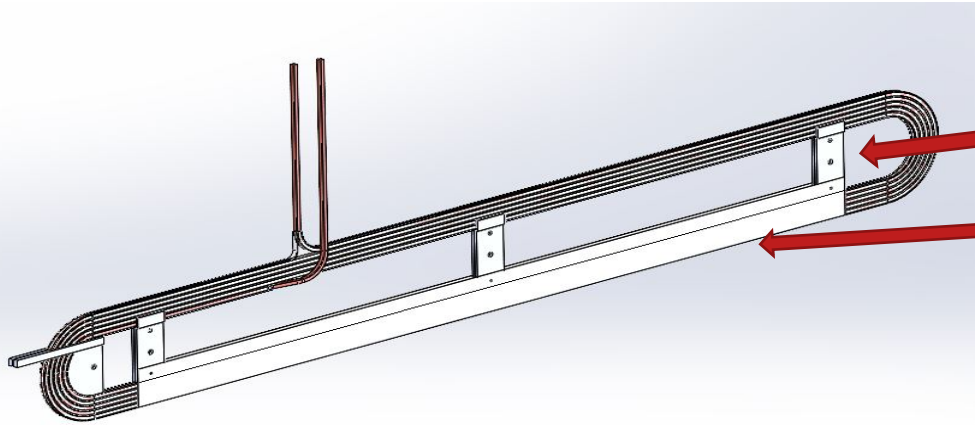

Aluminum Spacers- Machined and MasterBond EP33

Tungsten sheet .5 mm attached after spacers in coil  
By both 3 screws and MasterBond EP33

Machined Aluminum Z coil location bracket  
Glued and bolted after coil done potting

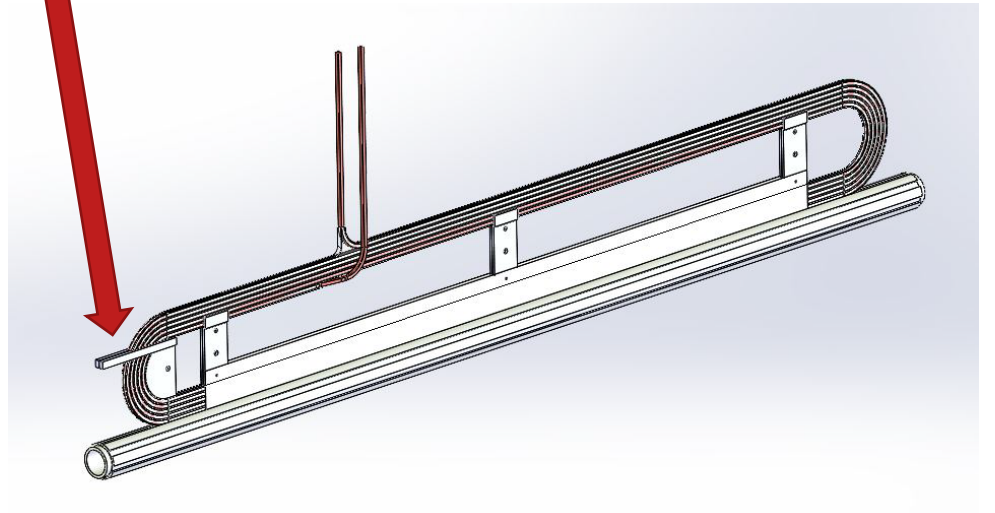
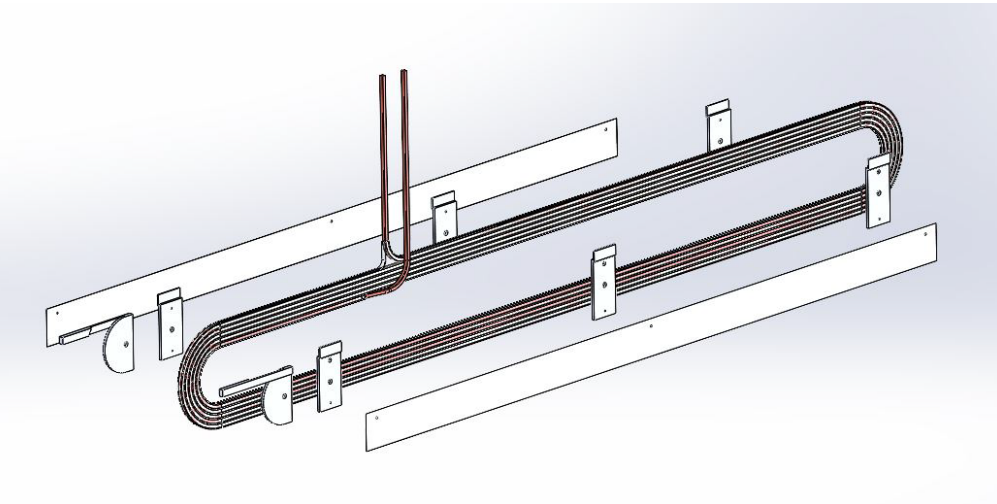

# Upstream Spectrometer Tungsten coil sheet in two bounce

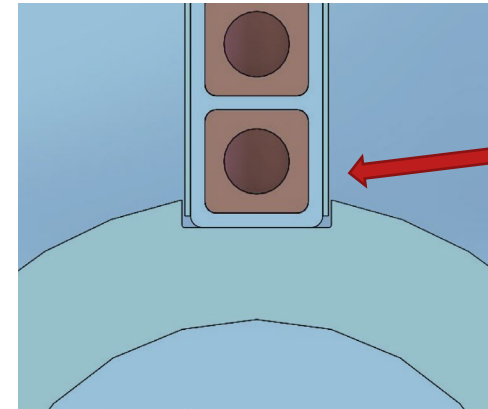
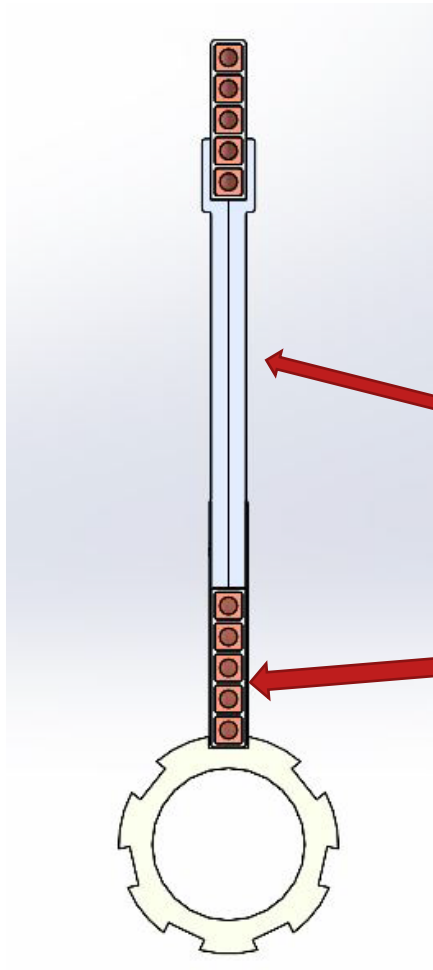
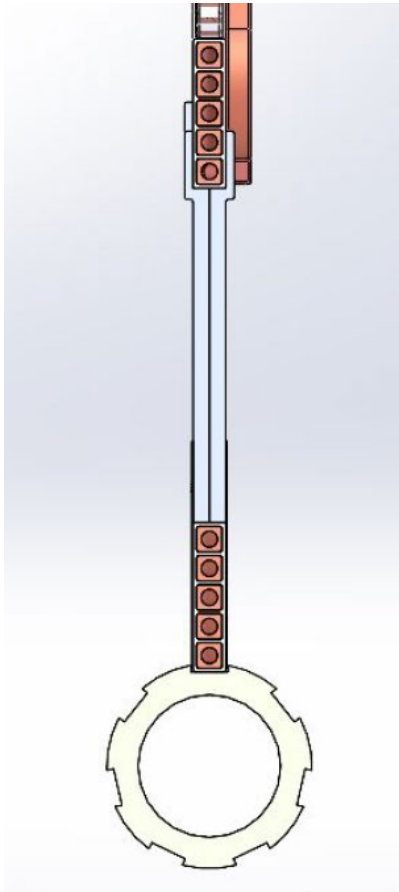

W sheet into 2 Bounce

Aluminum Spacers- Machined and MasterBond EP33

Tungsten sheet .5 mm attached after spacers in coil

# Status of Upstream Toroid system and CD-3a items

---

- Priority changed on final engineering to produce final designs and documentation
- CD-3a items include Sieve, Blocker, two bounce shield, collimator #4 and coil subassembly and supports.
- Final drawings for upstream coil are in progress
- The goal would be to piggy back an order to ETI for the 7 coils and one spare.



# MOLLER Chamber to shielding clearance

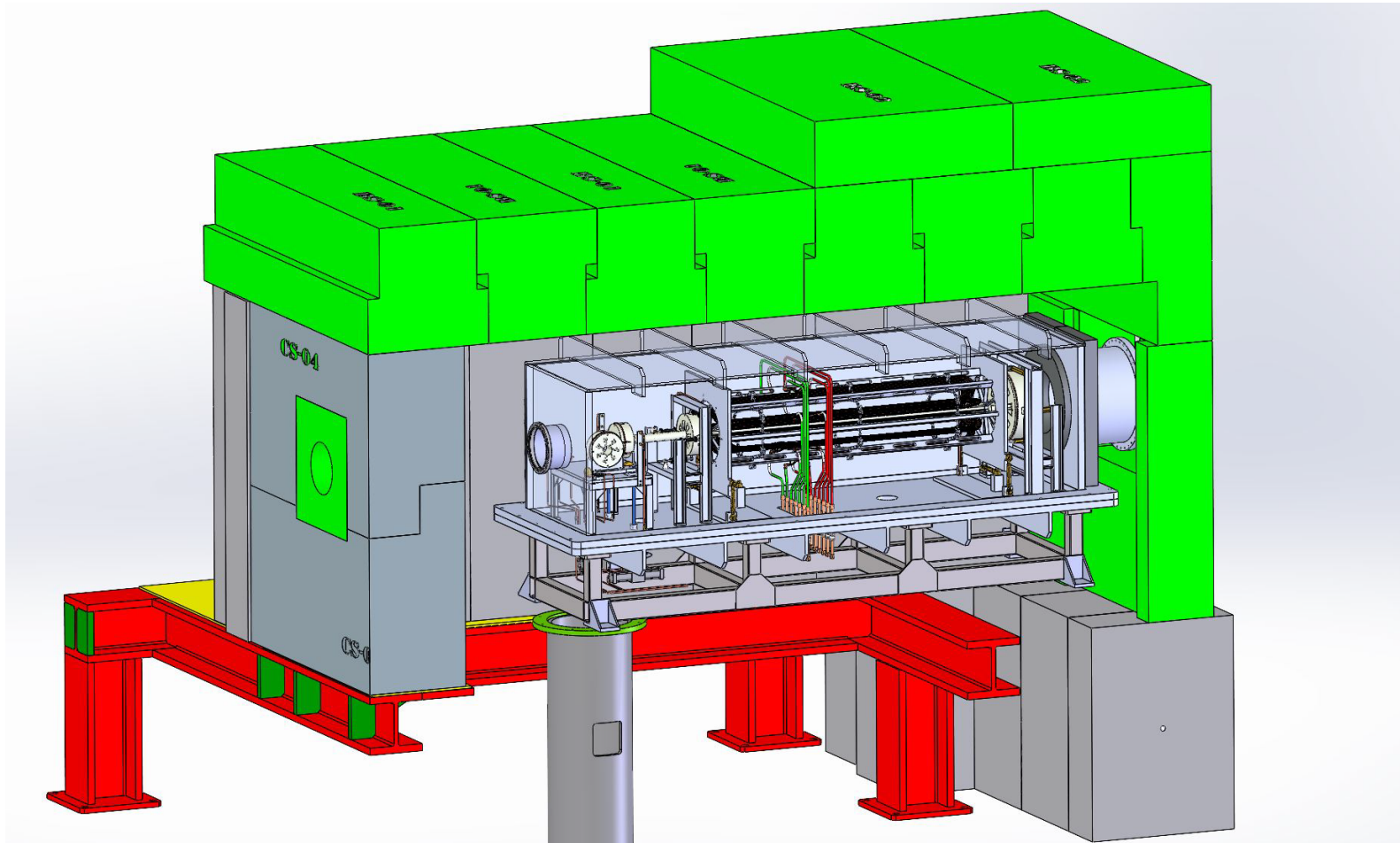

- Hardware to top of pivot = 90 mm
- Chamber frame to red steel = 320 mm
- Chamber top to shielding = 300 mm
- Chamber side to shielding = 500 mm
- Chamber front to shielding upstream = 1,100 mm

# Coil subsystem and two bounce shield

Coil support systems includes the Coil support frame, adjustment struts, two bounce shield, 7 coils plus current leads

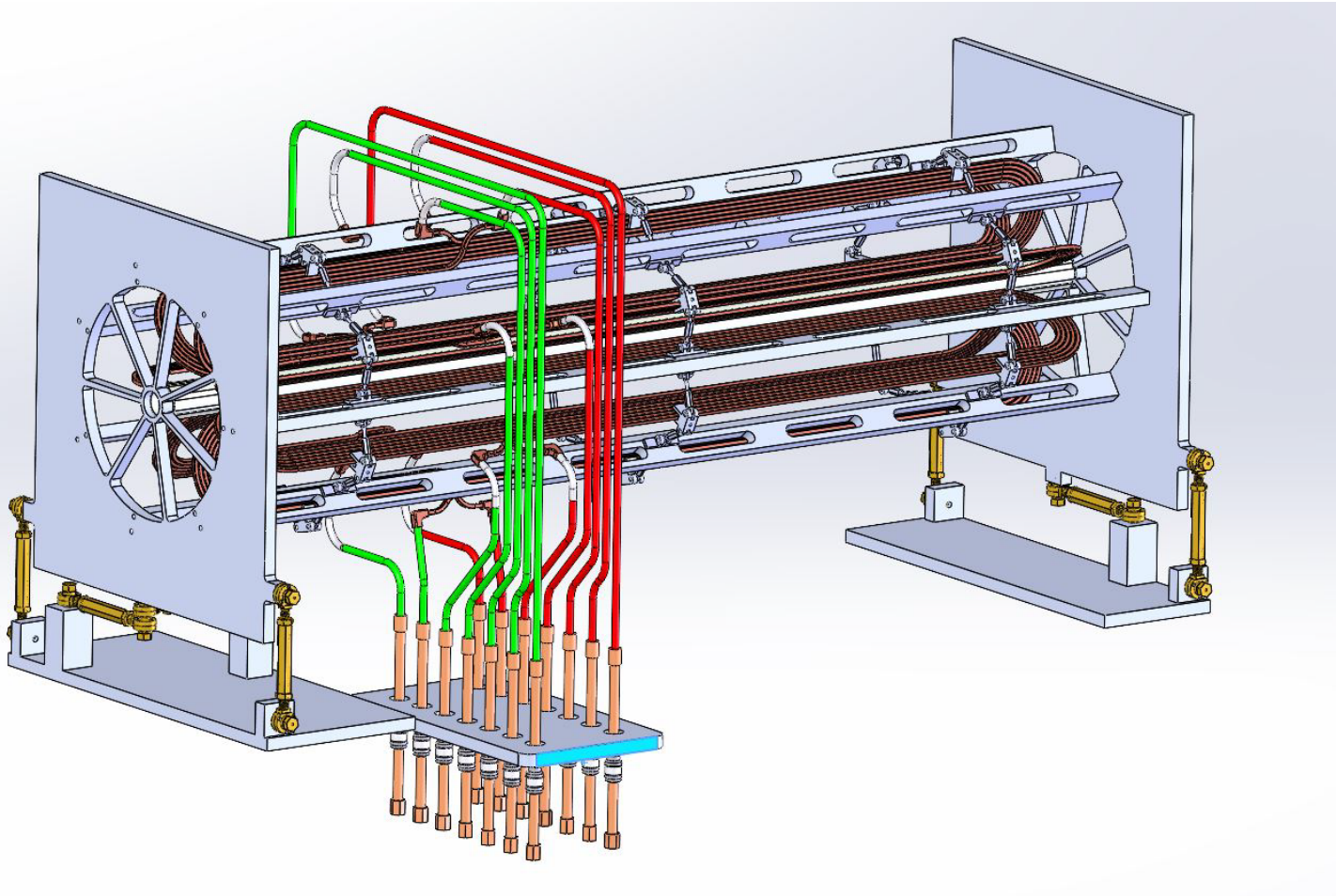

Detailed coil drawings and support stand are in final check approval.

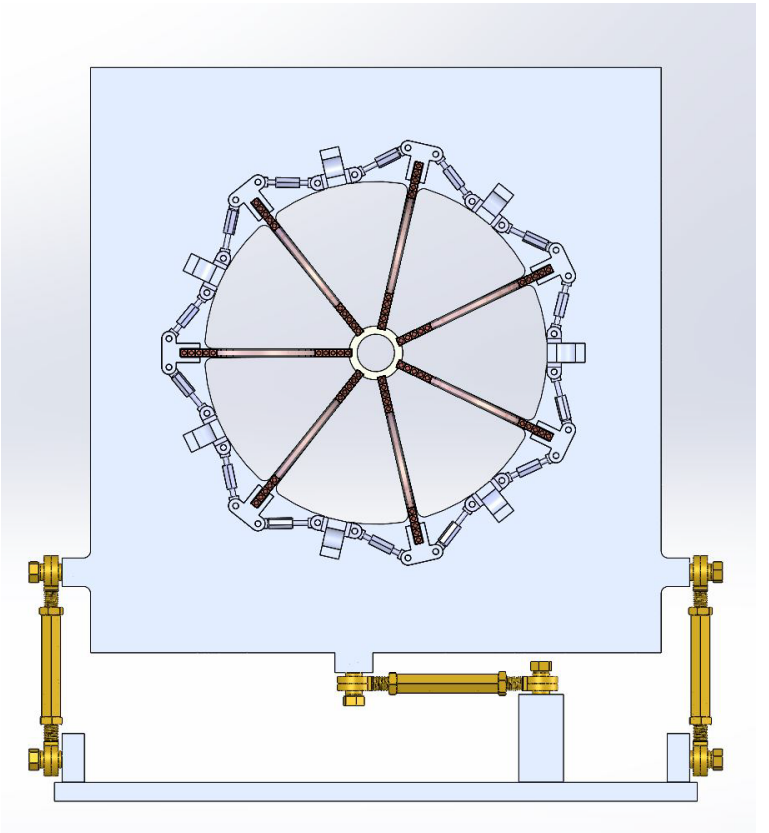

# Upstream chamber FEA

Model name: Vacuum Chamber Assembly Part  
Study name: Static 1(-Default-)  
Plot type: Static displacement Displacement1  
Deformation scale: 10

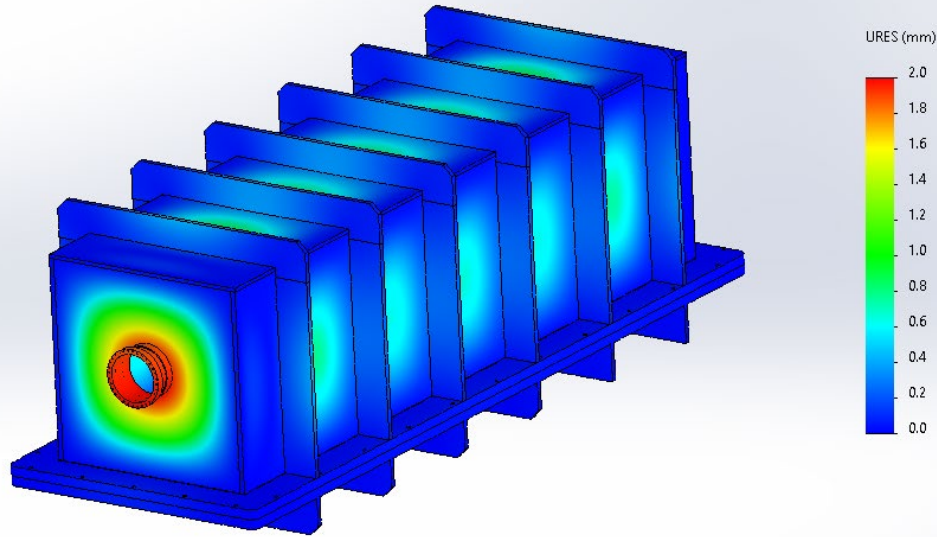

Model name: Vacuum Chamber Assembly  
Study name: Static 1(-Middle Feedthrough Plate-)  
Plot type: Static nodal stress Stress1  
Deformation scale: 10

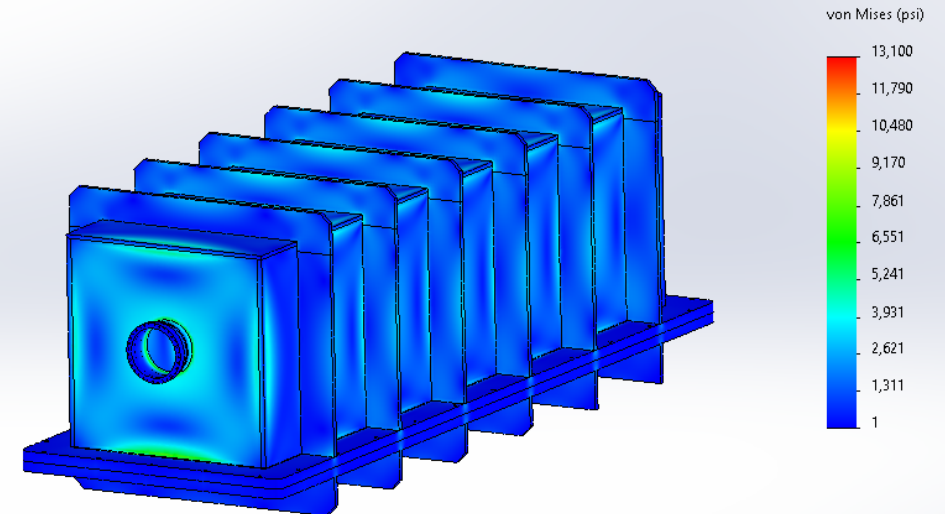

Resulting stress with allowable for ASME VIII code for 6061-T0. Following Jefferson Lab Pressure and Vacuum Systems Safety Program for chamber design. Approvals will be done in conjunction with Jefferson Design Authority. Results- 2 mm deflection and 6,500 psi stress

## EH&S and Summary

---

Upstream Torus chamber and enclosed hardware are specifically designed to meet the needs of the MOLLER experiment in making an ultra-precise measurement of the parity-violating asymmetry in Møller scattering.

All the hardware enclosed in the upstream vacuum chamber is specifically designed from four viewpoints:

1. Robust engineering designs that will require **no hands-on servicing** during the duration of the experiment to meet ALARA goals for engineered solutions.
2. Material selection that are both compatible with the high radiation flux and do not affect the experiment by giving false asymmetries. Consideration for end of experiment disassembly.
3. Alignment and moveable blockers that will not require checking during the experiment. All hardware is designed for low deflections and repeatable movement.
4. No instrumentation is contained inside the vacuum chamber at all. This is done so that if there is any failures or degrading, the measurement points are all outside the vacuum envelope and remote from the highest radiation areas.