

MOLLER Activation and Radiation Load Studies : Progress and Future Work

Rakitha Beminiwattha
LA Tech

Main Activities

- Radiation load on spectrometer (02.R-01)
- Preparations for activation studies (02.C-06)
 - Geometry implementation
 - Fixing code issues and GDML import failures

2016 Dec DR.02.C-06	Spectrometer/ Simulation	experimental time needs to be developed so that a plan can	Mammei*, Rakitha	working to import the rest of the shielding geometry. Juliette	[last update from Rakitha:	CD3	31-Dec-19	02.C-06	Quantify ra of n
2016 Dec DR.02.R-01	Spectrometer/ Simulation	The potential effects of radiation damage on the epoxy-potted spectrometer magnet coils should be assessed.	Juliette Mammei*, Rakitha Beminiwattha	an epoxy for the coil. Power per unit area for different locations of the coil has been generated. By the completion date, we can provide radiation damage in units of Neutron Fluence (n/m2) and rad/hr for	In Progress. [last update from Rakitha: 8/31/2019]	CD2	31-Oct-19	02.R-01	More ca radiatic s
2016 Dec	Magnet	readiness elements, with	H. Fenker	Director's Review. Milestone	Complete	CD1	Complete	02.R-02	

14	2016 Dec DR.02.C-06	Magnet	and the technical issues	Juliette Mammei			Open.	CD2	31-Mar-20	02.C-05	
15	2016 Dec DR.02.C-06	Spectrometer/ Simulation	An evaluation of material irradiation and activation vs experimental time needs to be developed so that a plan can be developed for access/handling.	Juliette Mammei*, Rakitha Beminiwattha	LaTech working on importing CAD/G4 geometry to FLUKA. Currently all the collimators and coils are imported and working to import the rest of the shielding geometry. Juliette will tabulate materials, components and regions to be evaluated. Depends on complete FLUKA simulation to		In Progress. [last update from Rakitha: 8/31/2019]	CD3	31-Dec-19	02.C-06	Quantify ra of p
	2016 Dec DR.02.R-01	Spectrometer/	The potential effects of radiation damage on the	Juliette Mammei*,	an epoxy for the coil. Power per unit area for different locations of the coil has been		In Progress.				More ca

Simulation : Activation Studies

- **Priority 1**
 - Setup the FLUKA simulation → Implement the MOLLER geometry – **ongoing at LaTech**
- **Priority 2**
 - Start estimating activations for various components – **ongoing at LaTech**
- One student trying to complete FLUKA simulation Only partially setup : See next few slides
 - Resolving technical issues with FLUKA
 - Fixing imported GDML volumes

Geometry Updates

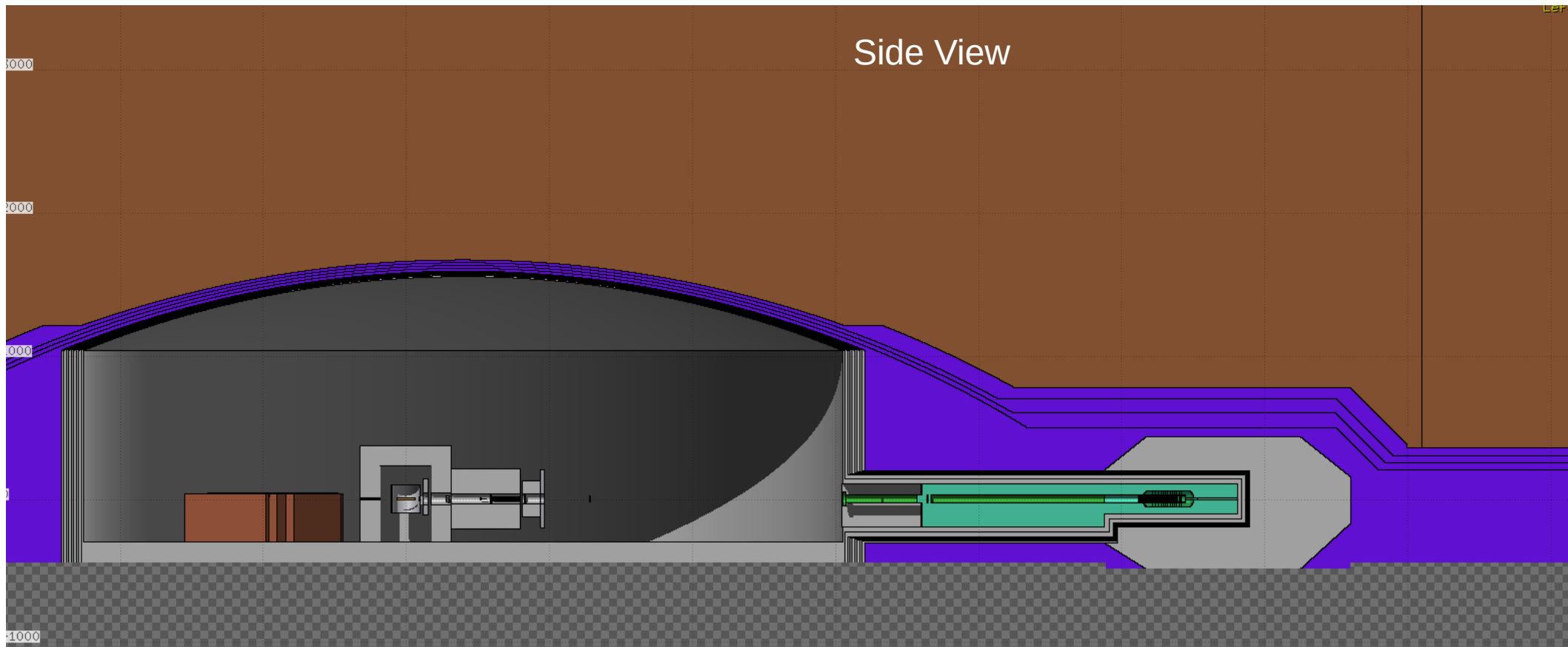

Geometry Updates

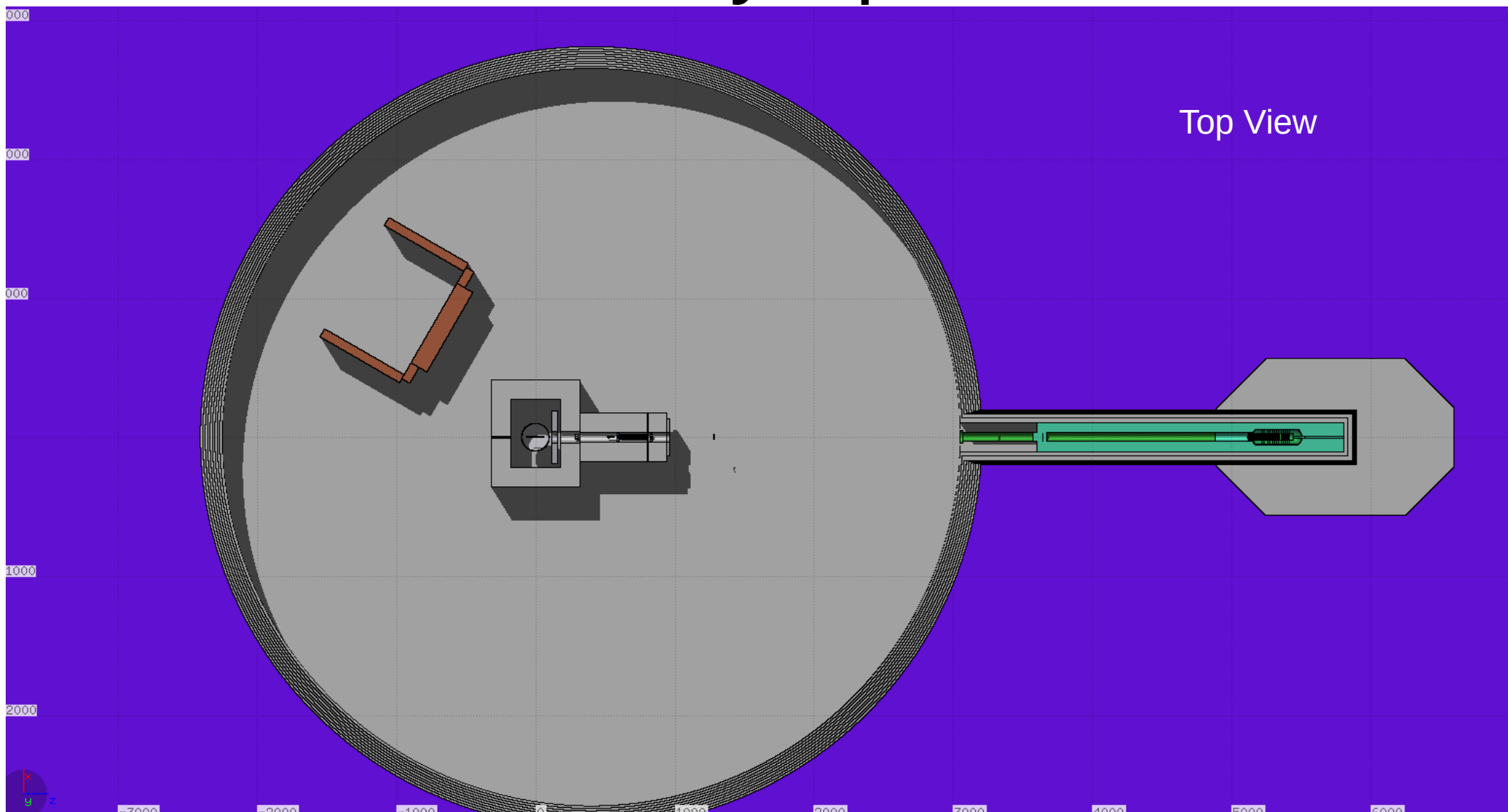

Geometry Updates

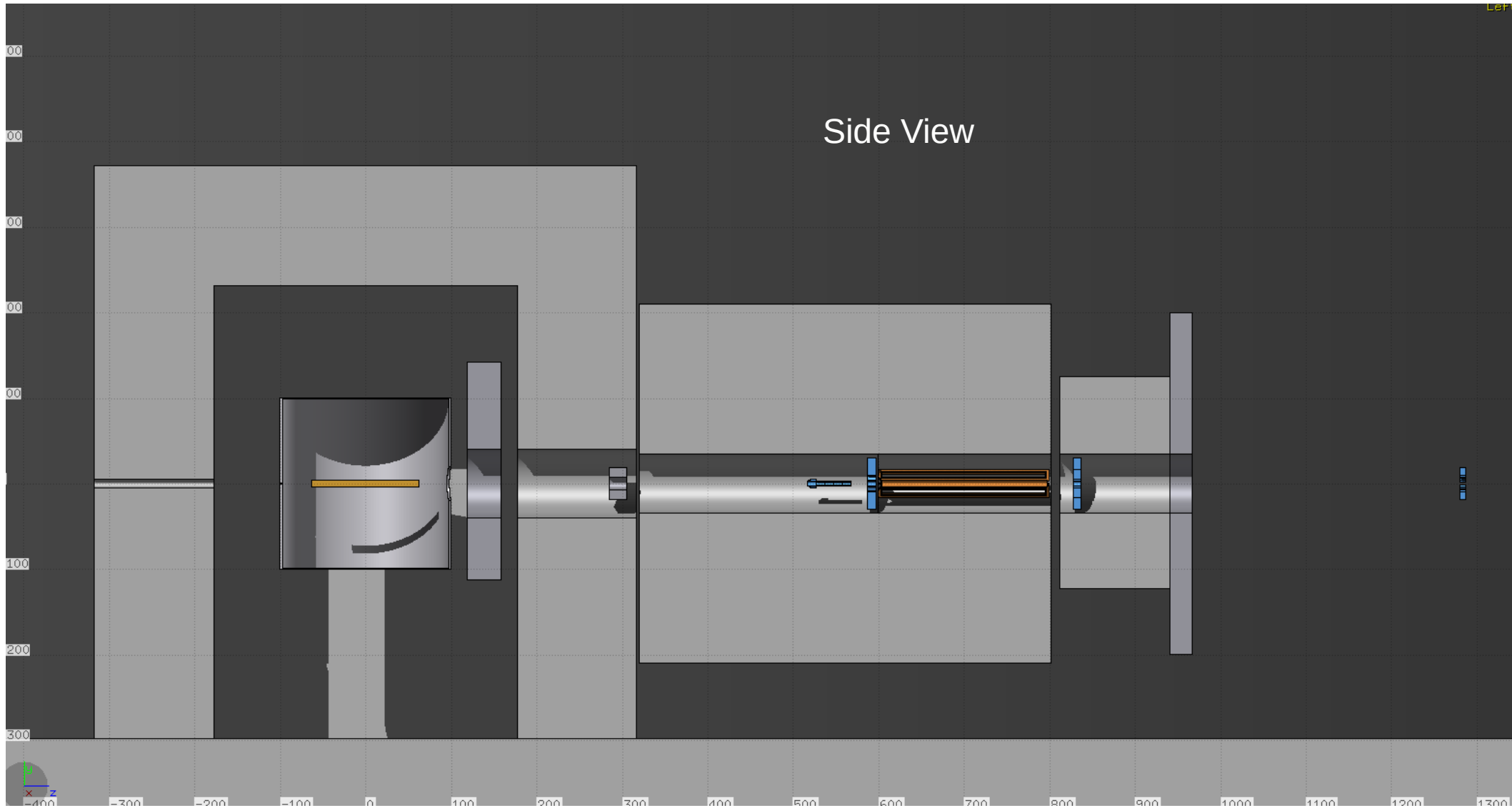

Geometry Updates

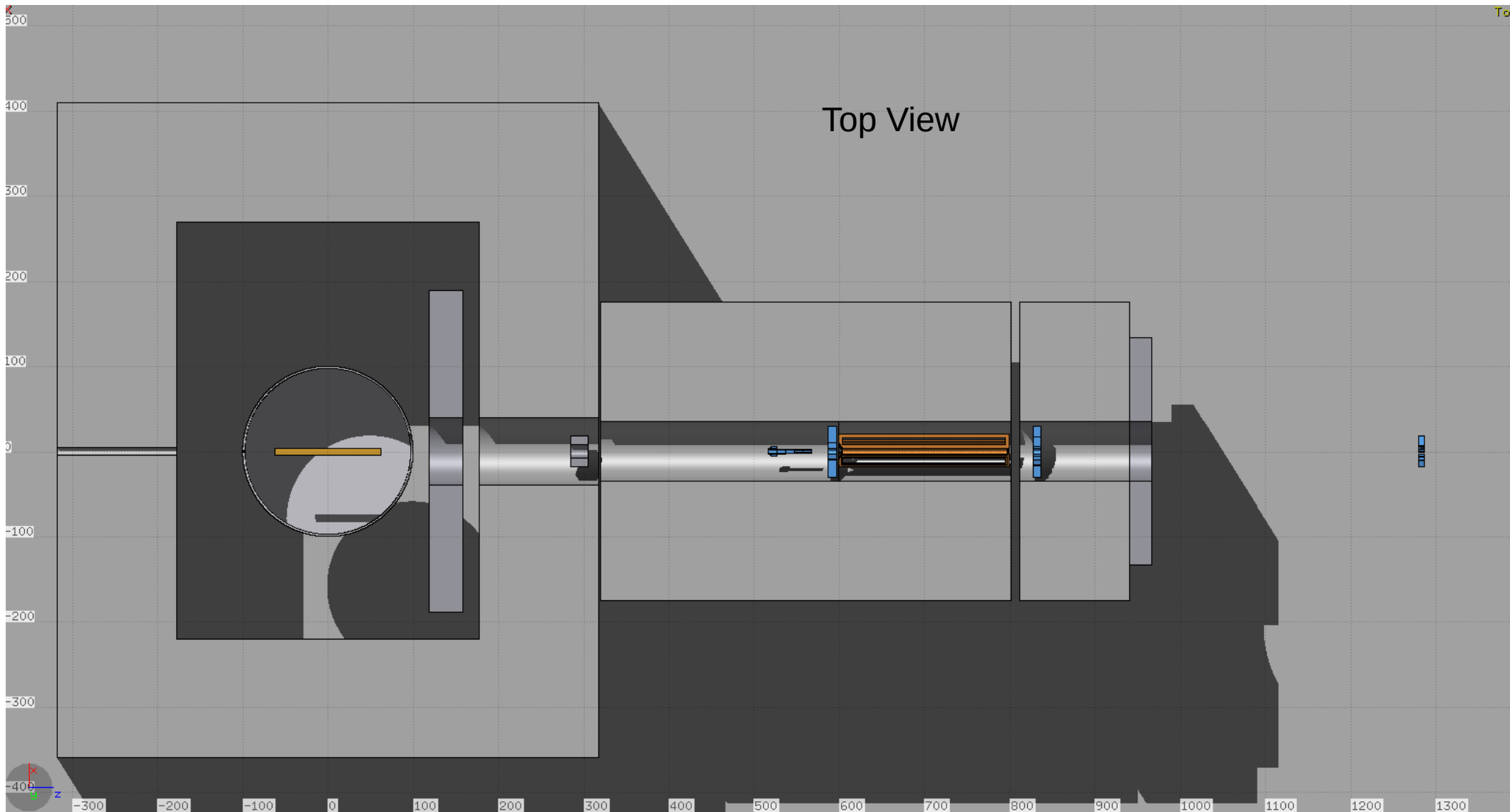

5/14/20

MOLLER Collaboration Meeting

Coil Geometry

We imported downstream coil geometry and implemented in FLUKA but in this configuration we cannot run the simulation due to geometry sub-elements reaching maximum limit

The geometry that can run does not have downstream coil geometry, as shown in earlier slides

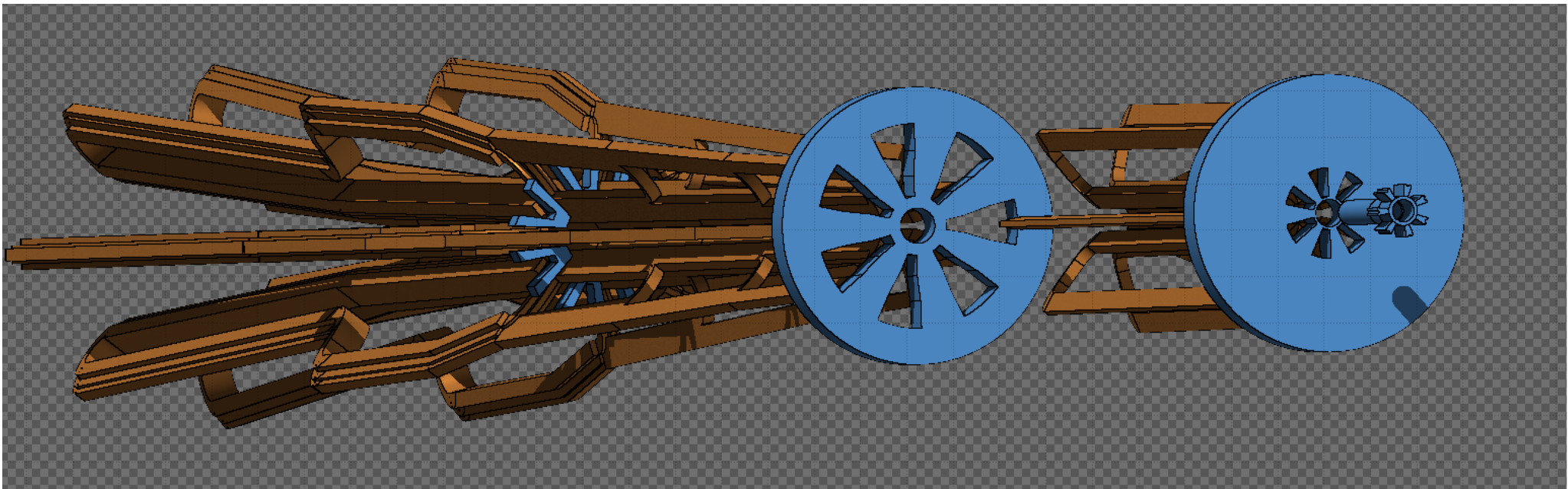

Spectrometer Radiation Load

Assuming all the incident energy on the coil is deposited we made following estimations

- Hot spot on Upstream Torus coils : 86 mW/cm²
- Assuming 334 days @ 60 uA : 6.1×10^9 Rad = 61 MGy
- Rest of the Upstream Torus coils : 2×10^9 Rad = 20 MGy
- Downstream Torus coils : 0.86 mW/cm²
 - 6.1×10^7 Rad = 0.61 MGy

Energy Deposit Map

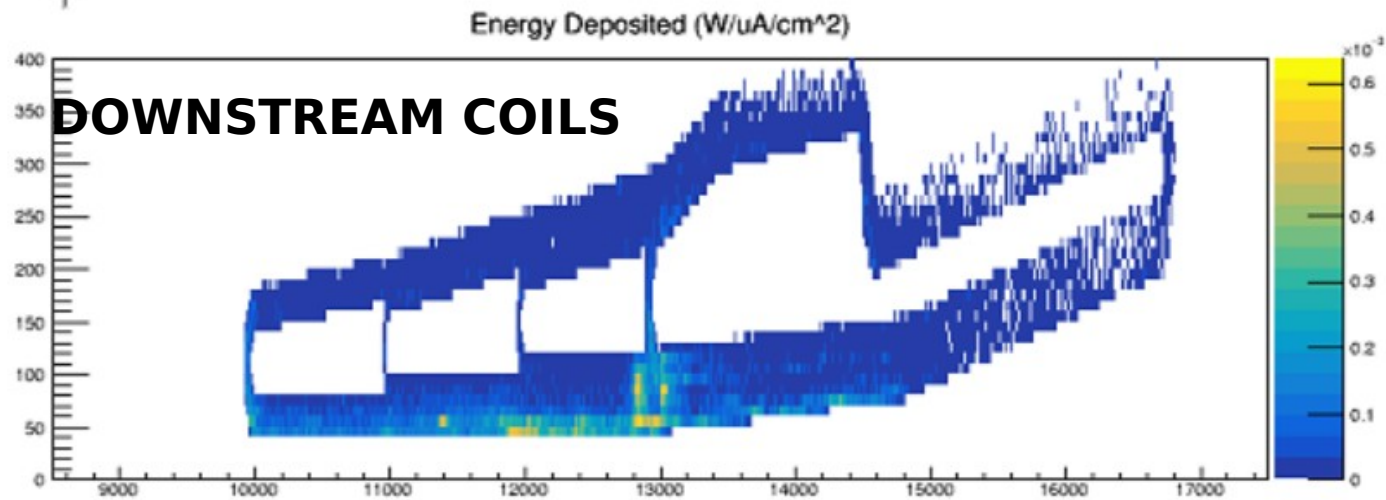
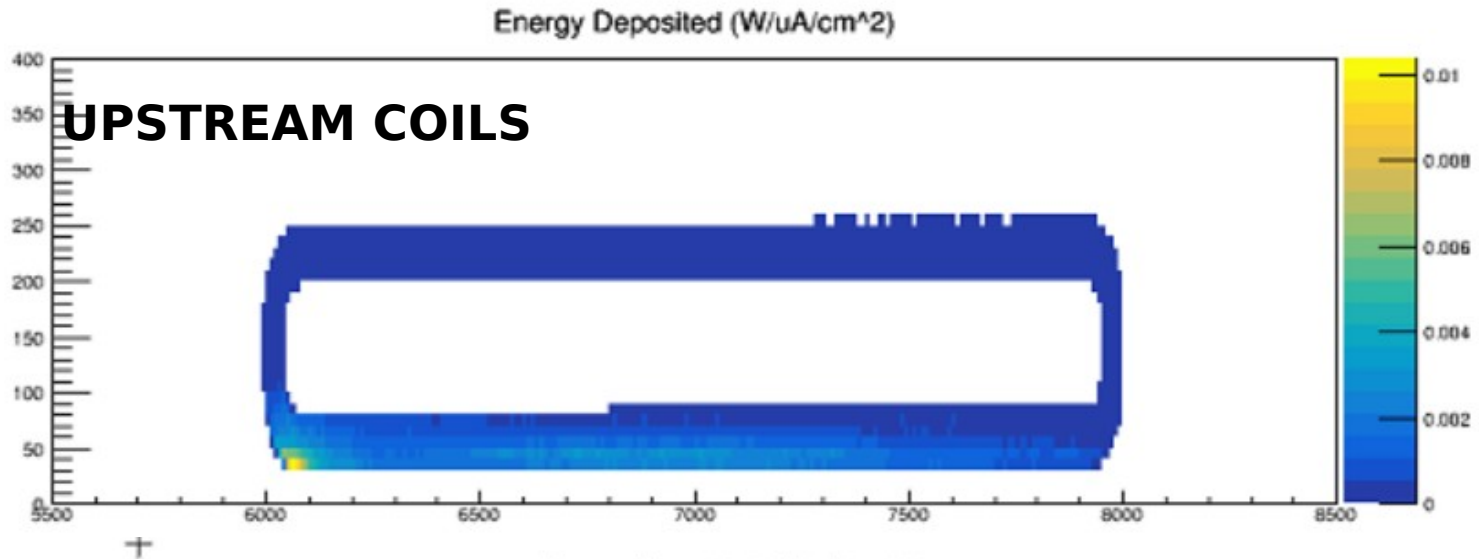

Spectrometer Radiation Load

- In 2018 we have completed initial estimates for the radiation dose on coil epoxy
- **We based these numbers assuming total radiation incident on the coil surface is completely absorbed by the coils**
- **This is only an upper limit** estimation. based on this analysis we found that radiation dose on upstream coil nose is **86 mW/cm²** (the hot spot).
- The total radiation dose **at the hot spot is 61 MGy** during 334 days at 60 uA.
- The rest of the upstream torus coils will receive 20 MGy. The **downstream torus coils will receive 0.61 MGy.**
- **Based on test data provided by CTD (see last slide) our worse case scenario is well below epoxy radiation damage limits.**

Epoxy Resin Tolerance to Radiation

[Ref. Haight, A.E., Haynes, M. W. , 'High Shear-Strength Electrical Insulations for Plasma Confinement Magnets', 1MOr3C-02, Work supported by the U.S. Department of Energy under Grant DE-SC0007668 - using the TRIGA reactor at ATI, Vienna, 80% gamma, 20%

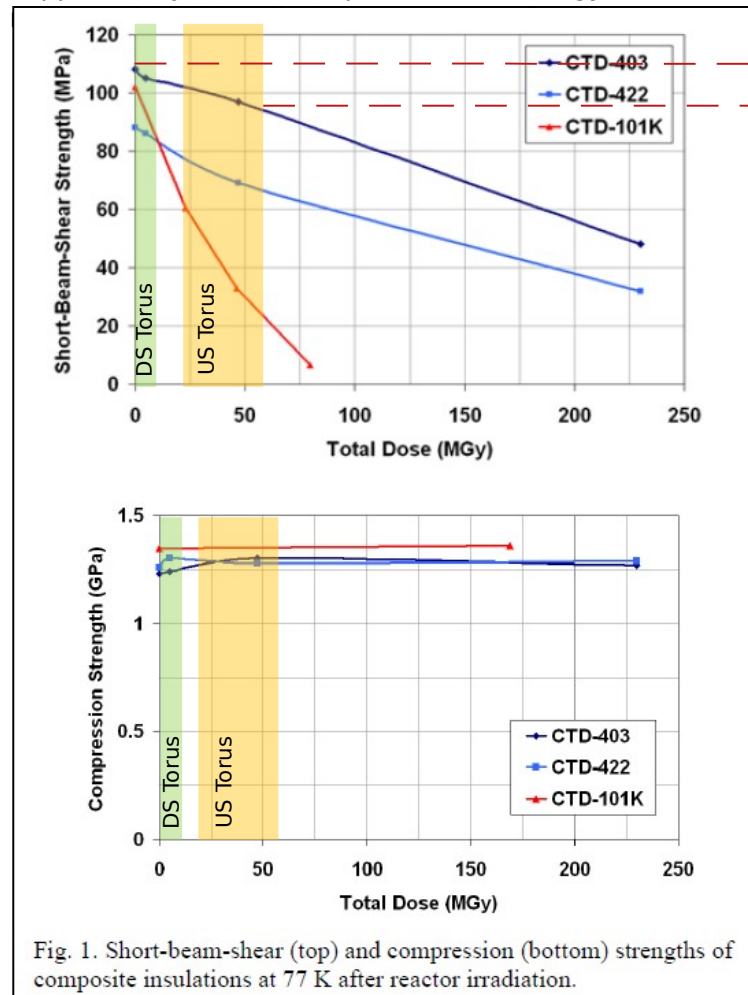

Worst case: Approx. 13% decrease in shear strength for CTD403

Conclusion should not be an issue for CTD 403

From Ruben Fair

Fig. 1. Short-beam-shear (top) and compression (bottom) strengths of composite insulations at 77 K after reactor irradiation.

Next Steps

Immediate Plans

- Since last analysis, radiation shielding and experiment configuration were changed for experiment optimizations. We will use the latest Jlab designed coil geometry. Therefore we will perform the epoxy dose estimation for our current experiment design as well as for the offset coil design to see worse case radiation dose on the coils. We will again estimate upper limit for radiation dose.

Long term plans

- We will add a single layer of epoxy (1 mm) on top of the copper coils and fill epoxy between coils. We will use G10 epoxy for our simulation.

Summary

- FLUKA geometry implementation is on going
 - Import shielding blocks, fixing DS coils, verify magnetic fields, etc.
- We will have to implement a simplified design of downstream coil in FLUKA
- Magnetic field verification with Geant4 needs to be done
- The geometry and magnetic field implementation code will soon be available in github

Supplementary

Preliminary Activation Studies

Activation of Collimator 1 and 2 of MOLLER Experiment

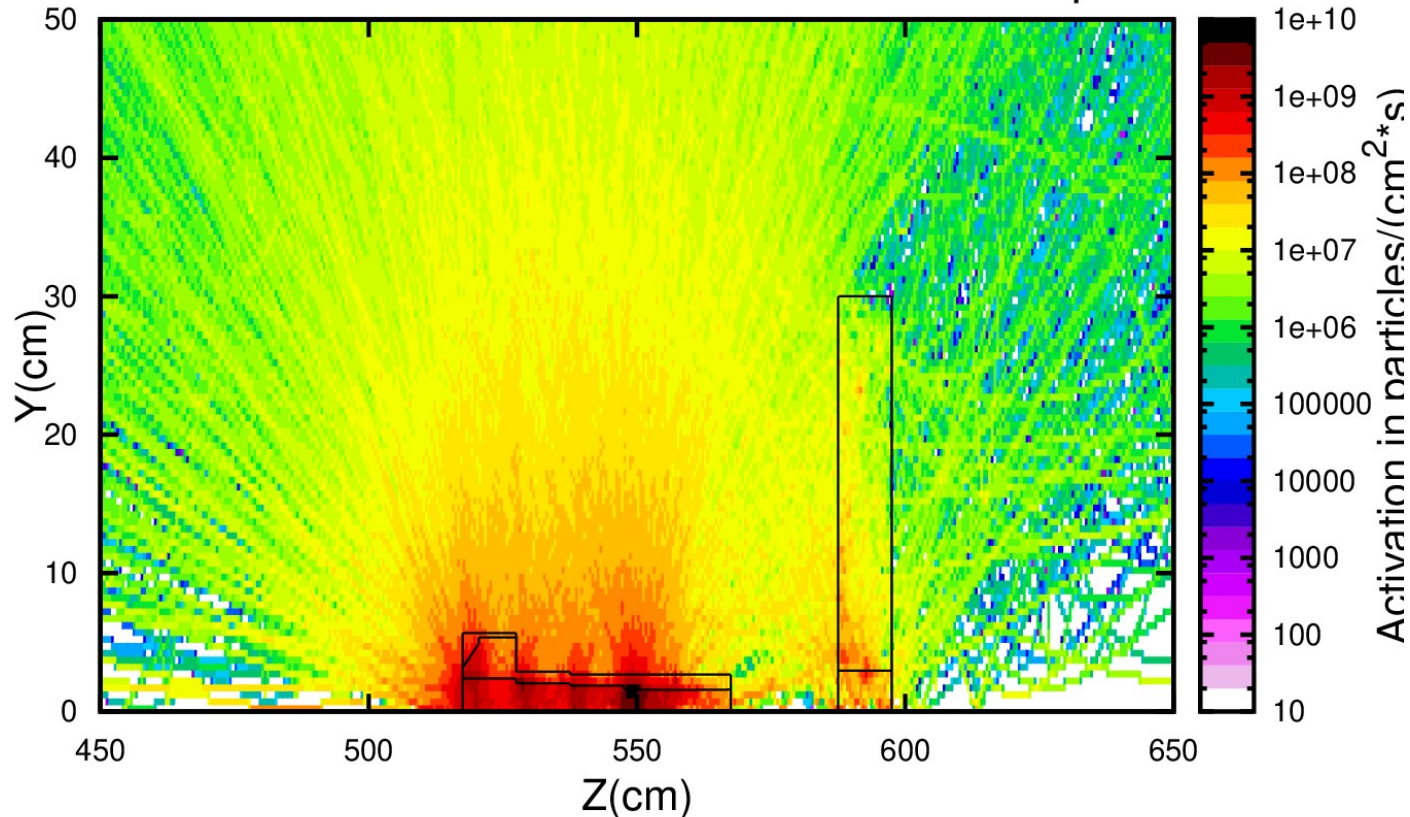

Activation after 1 hour in the col1 and 2 running x days
Units are particles/cm²*s and having trouble converting to rem/hour

Preliminary Activation Studies

Activation of Collimator 1 and 2 of MOLLER Experiment

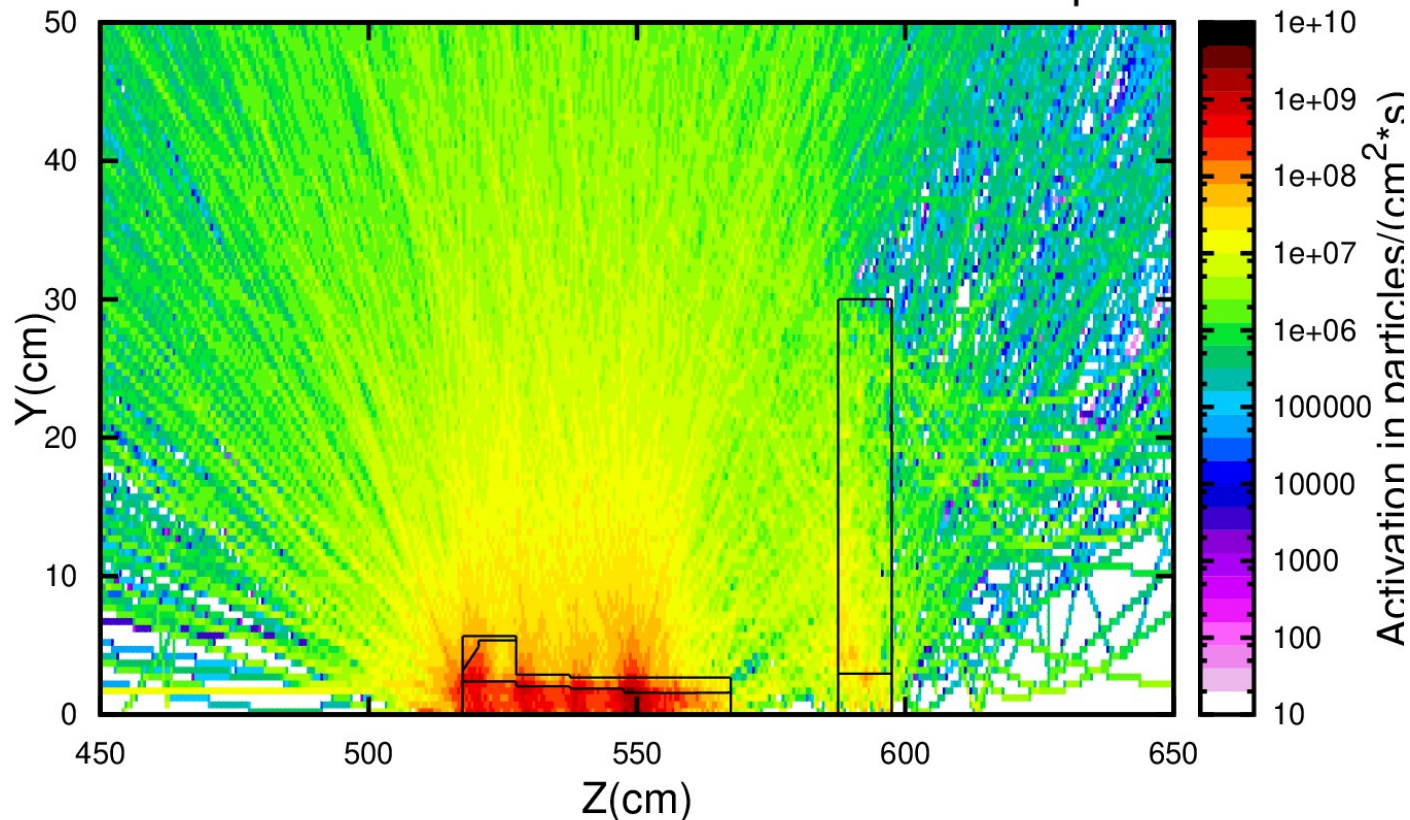

Activation after 1 day in the col1 and 2 running x days
Units are particles/cm²*s and having trouble converting to rem/hour

Preliminary Activation Studies

Activation of Collimator 1 and 2 of MOLLER Experiment

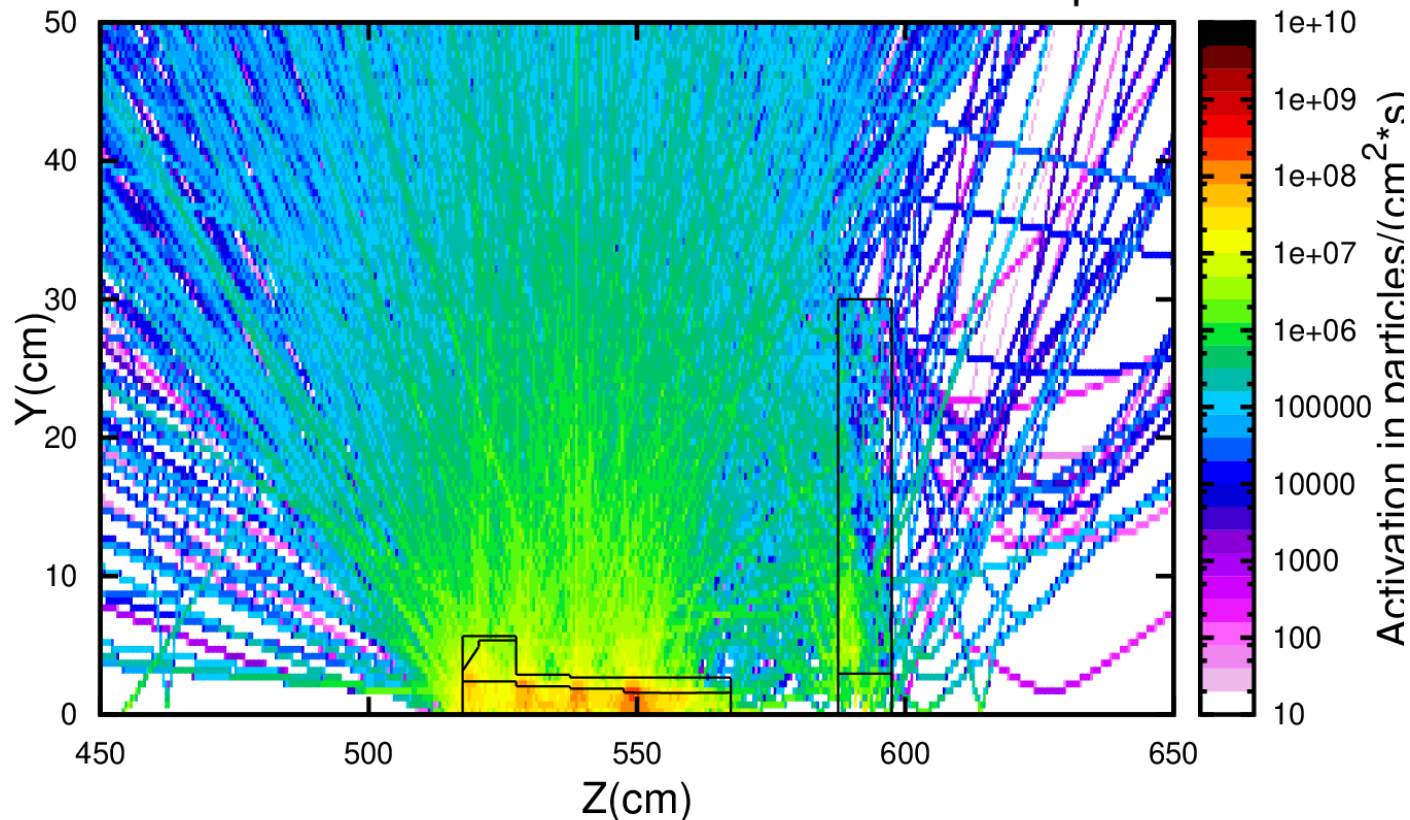

Activation after 1 month in the col1 and 2 running x days
Units are particles/cm²*s and having trouble converting to rem/hour

Preliminary Activation Studies

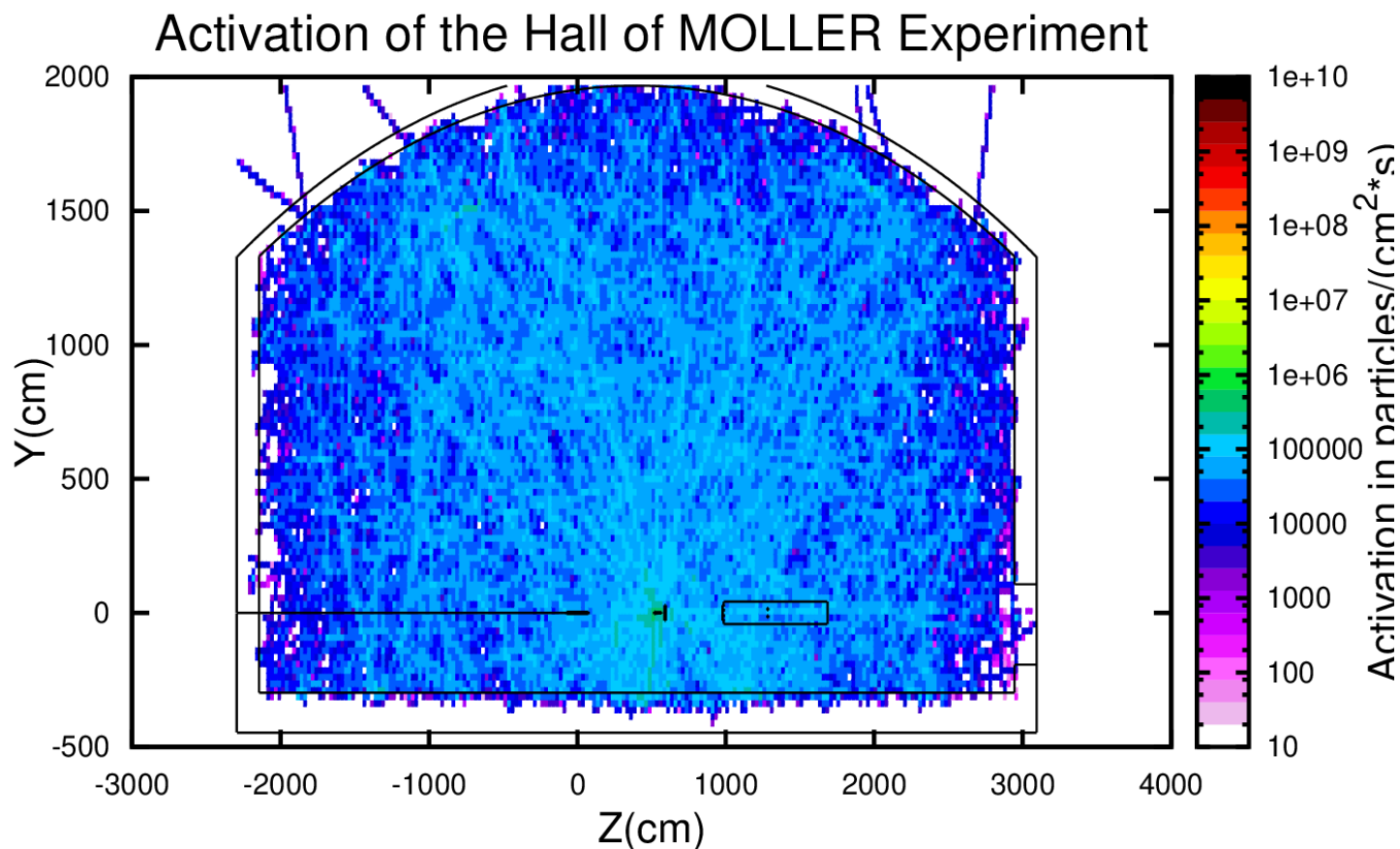

Activation after 1 hour in the hall after running x days
Units are particles/cm²*s and having trouble converting to rem/hour

Preliminary Activation Studies

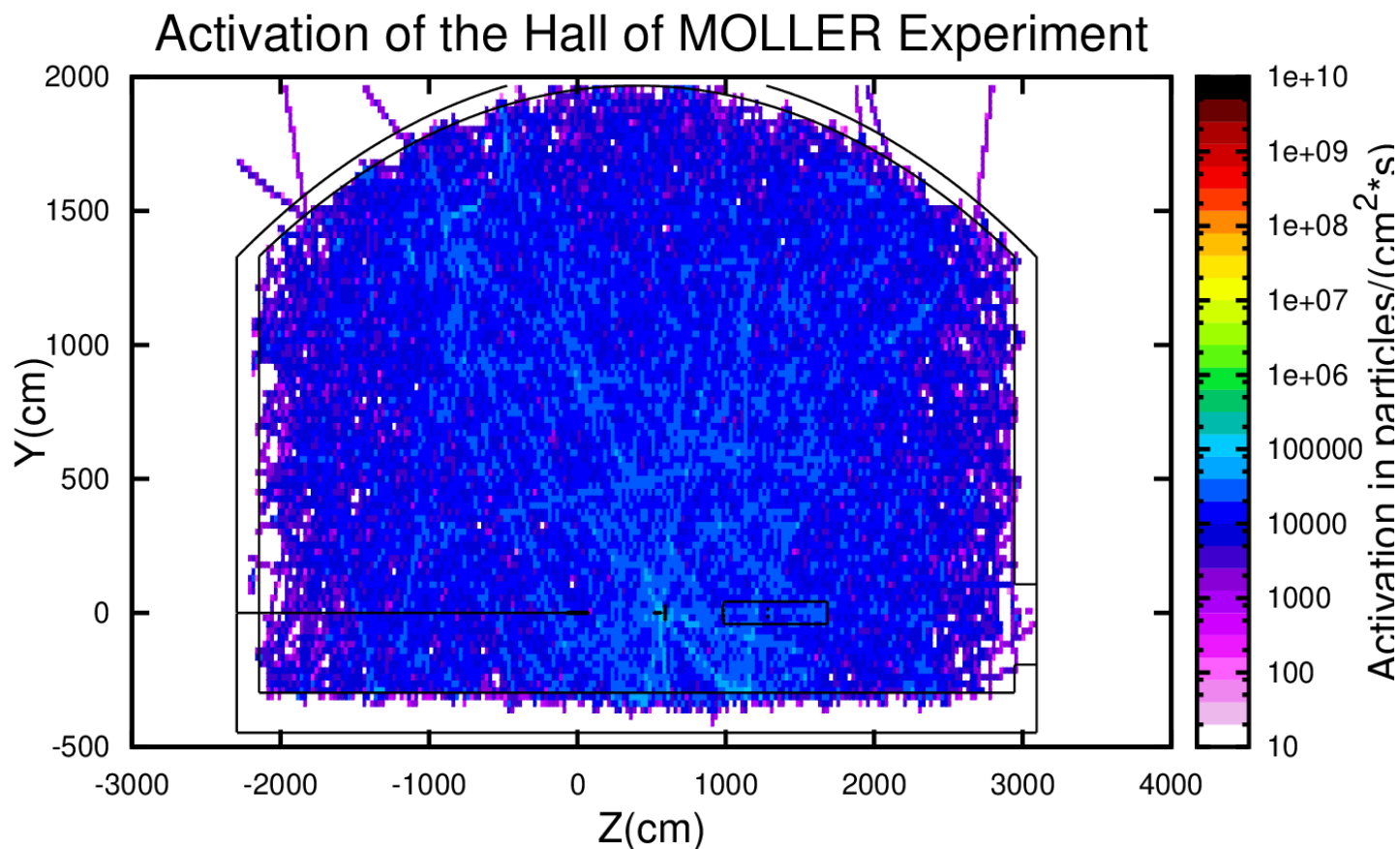

Activation after 1 day in the hall after running x days
Units are particles/cm²*s and having trouble converting to rem/hour

Preliminary Activation Studies

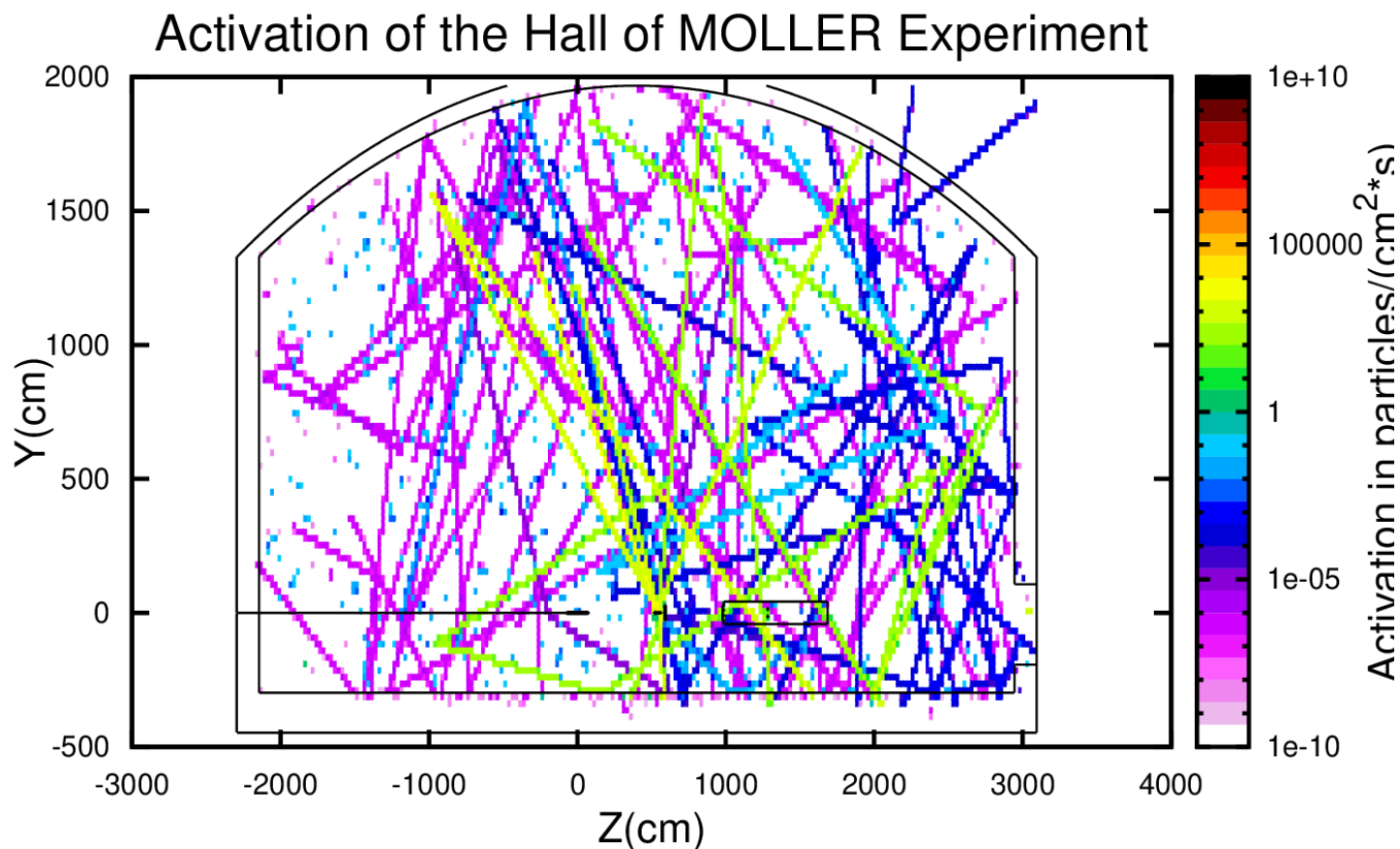

Activation after 1 month in the hall after running x days
Units are particles/cm²*s and having trouble converting to rem/hour

Simulation : Activation Studies

- Magnetic fields (upstream and downstream) are Imported
- Now validating the magnetic field implementation
- Once magnetic field is verified, realistic activation studies can be performed

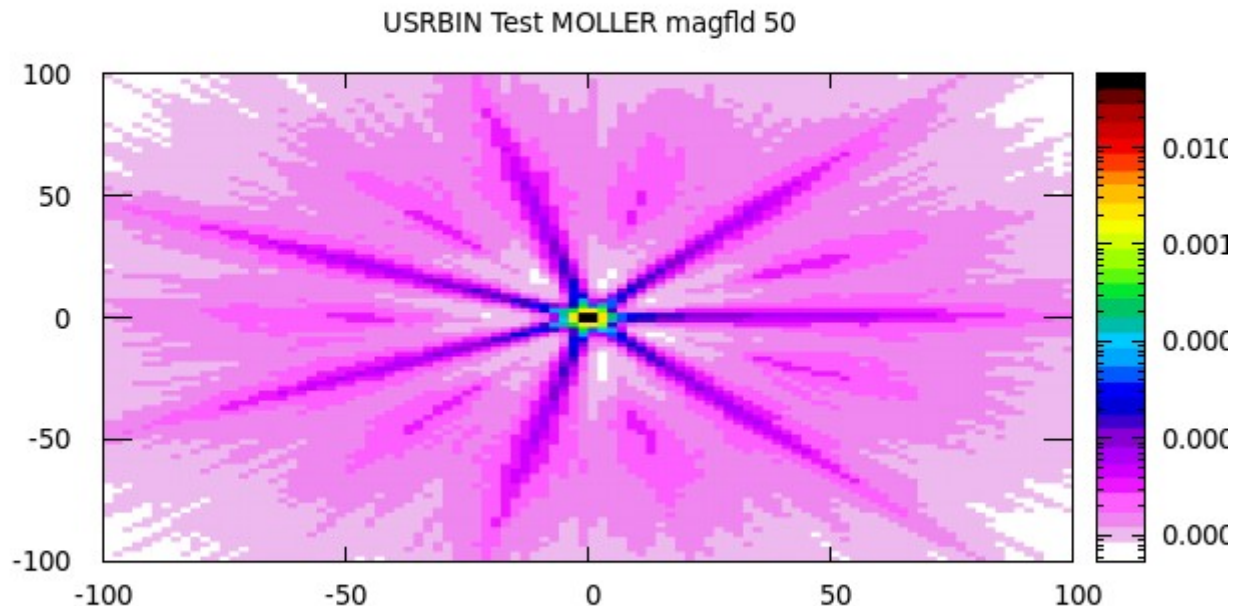

Simulation : Activation Studies

- Some issues to resolve
 - Beam on target FLUKA simulation did not match the energy spectrum at the detector plane (compared with Geant4)
- Ran 5.5 GeV at the average scattered angle initiated at the center of the target,
- More checks will be done

